



# FCC 47 CFR PART 15 SUBPART B TEST REPORT

for

**Laptop Computer**

**MODEL: XO-4 HS; XO-4; XO-4 HS Touch; XO-4 Touch**

Test Report Number:  
T130222L03-D

Issued for

Quanta Computer Inc.

No. 188, Wen Hwa 2nd RD., Kuei Shan Hsiang, Taoyuan Hsien, Taiwan, R.O.C.

Issued By:

Compliance Certification Services Inc.

Linkuo Laboratory

No.81-1, Lane 210, Bade 2nd Rd., Lujhu Township,  
Taoyuan County 33841, Taiwan, R.O.C.

TEL: 886-3-324-0332

FAX: 886-3-324-5235

E-Mail: [service@ccsrf.com](mailto:service@ccsrf.com)

Issued Date: March 6, 2013



**Note:** This report shall not be reproduced except in full, without the written approval of Compliance Certification Services Inc. This document may be altered or revised by Compliance Certification Services Inc. personnel only, and shall be noted in the revision section of the document. The client should not use it to claim product endorsement by TAF, A2LA, NIST or any government agencies. The test results in the report only apply to the tested sample.



**Revision History**

Rev.	Issue Date	Revisions	Effect Page	Revised By
00	March 6, 2013	Initial Issue	All	Landy Huang



**TABLE OF CONTENTS**

**1 TEST RESULT CERTIFICATION ..... 4**

**2 EUT DESCRIPTION ..... 5**

**3 TEST METHODOLOGY ..... 7**

    3.1. DECISION OF FINAL TEST MODE ..... 7

    3.2. EUT SYSTEM OPERATION ..... 7

**4 SETUP OF EQUIPMENT UNDER TEST ..... 8**

    4.1. DESCRIPTION OF SUPPORT UNITS ..... 8

    4.2. CONFIGURATION OF SYSTEM UNDER TEST ..... 8

**5 FACILITIES AND ACCREDITATIONS ..... 9**

    5.1. FACILITIES ..... 9

    5.2. ACCREDITATIONS ..... 9

    5.3. MEASUREMENT UNCERTAINTY ..... 10

**6 CONDUCTED EMISSION MEASUREMENT ..... 11**

    6.1. LIMITS OF CONDUCTED EMISSION MEASUREMENT ..... 11

    6.2. TEST INSTRUMENTS ..... 11

    6.3. TEST PROCEDURES ..... 12

    6.4. TEST SETUP ..... 13

    6.5. DATA SAMPLE: ..... 13

    6.6. TEST RESULTS ..... 14

**7 RADIATED EMISSION MEASUREMENT ..... 16**

    7.1. LIMITS OF RADIATED EMISSION MEASUREMENT ..... 16

    7.2. TEST INSTRUMENTS ..... 18

    7.3. TEST PROCEDURES ..... 19

    7.4. TEST SETUP ..... 20

    7.5. DATA SAMPLE: ..... 21

    7.6. TEST RESULTS ..... 22

**8 PHOTOGRAPHS OF THE TEST CONFIGURATION ..... 26**

**APPENDIX 1: PHOTOGRAPHS OF EUT ..... 29**



# 1 TEST RESULT CERTIFICATION

<b>Product:</b>	Laptop Computer
<b>Model:</b>	XO-4 HS; XO-4; XO-4 HS Touch; XO-4 Touch
<b>Brand:</b>	OLPC
<b>Applicant:</b>	<b>Quanta Computer Inc.</b> No. 188, Wen Hwa 2nd RD., Kuei Shan Hsiang, Taoyuan Hsien, Taiwan, R.O.C.
<b>Manufacturer:</b>	<b>Quanta Computer Inc.</b> No. 188, Wen Hwa 2nd RD., Kuei Shan Hsiang, Taoyuan Hsien, Taiwan, R.O.C.
<b>Tested:</b>	February 22 ~ March 4, 2013
<b>Test Voltage:</b>	120VAC, 60Hz

EMISSION			
Standard	Item	Result	Remarks
FCC 47 CFR Part 15 Subpart B ICES-003 Issue 5: 2012 ANSI C63.4-2009	Conducted (Main Port)	PASS	Meet Class B limit
	Radiated	PASS	Meet Class B limit

Note: 1. The statements of test result on the above are decided by the request of test standard only; the measurement uncertainties are not factored into this compliance determination.  
 2. The information of measurement uncertainty is available upon the customer's request.

Deviation from Applicable Standard
None

The above equipment has been tested by Compliance Certification Services Inc., and found compliance with the requirements set forth in the technical standards mentioned above. The results of testing in this report apply only to the product/system, which was tested. Other similar equipment will not necessarily produce the same results due to production tolerance and measurement uncertainties.

Approved by:

Reviewed by:

Bill Cheng  
Section Manager

Angel Hu  
Section Manager



## 2 EUT DESCRIPTION

<b>Product</b>	Laptop Computer		
<b>Model</b>	XO-4 HS; XO-4; XO-4 HS Touch; XO-4 Touch		
<b>Brand</b>	OLPC		
<b>Applicant</b>	Quanta Computer Inc.		
<b>Serial Number</b>	T130222L03		
<b>Identify Date</b>	February 22, 2013		
<b>EUT Power Rating</b>	12VDC, 2.0A / 13.5VDC, 1.85A		
<b>Power Adapter Manufacturer</b>	Bestec	<b>Model</b>	NA0241WAA
			NA0241WEA
			BT-AG250SDF
	Darfon	<b>Model</b>	BX24-1203 (X= U or P)
			BB0J-C
<b>AC Power Adapter Rating</b>	<b>For NA0241WAA; NA0241WEA</b> I/P: 100-240VAC, 1.0A, 50-60Hz O/P: 12VDC, 2.0A		
	<b>For BT-AG250SDF</b> I/P:100-240VAC, 0.4 A, 50-60Hz O/P: 13.5VDC, 1.85A		
	<b>For BX24-1203 (X= U or P)</b> I/P: 100-240VAC, 0.7A, 50-60Hz O/P: 12VDC, 2.0A		
	<b>For BB0J-C</b> I/P: 100-240VAC, 1.0 A, 50-60Hz O/P: 13.5VDC, 1.85A		
<b>AC Power Cable Type</b>	<b>For BT-AG250SDF; BB0J-C</b> Unshielded, 1.8m (Detachable) to Power Adapter		
<b>DC Power Cable Type</b>	Unshielded, 1.8m (Non-Detachable) at Power Adapter		
<b>EMMC</b>	4GB/8GB		
<b>Memory Capacity</b>	1GB/2GB		



<b>CPU Manufacturer</b>	Marvell	<b>Model</b>	PXA2128 (1.0GHz)
			PXA2128 (1.2GHz)
<b>7.5" LCD Panel Manufacturer</b>	CHIMEI	<b>Model</b>	G075ADE-T01
<b>Camera Manufacturer</b>	SUYIN	<b>Model</b>	CM0316-OLPC01
			CM031B-SE01
	FOXLINK	<b>Model</b>	FE03FF-317H
<b>WLAN Manufacturer</b>	QMI	<b>Model</b>	EM113-MV
	Liteon	<b>Model</b>	WCBN603MH
<b>Battery Manufacturer</b>	BYD	<b>Model</b>	CL1
	STL	<b>Model</b>	XO-1

**I/O PORT**

I/O PORT TYPES	Q'TY	TESTED WITH
1. HDMI Port	1	1
2. USB 2.0 Port	2	2
3. Audio Port	2	2
4. Memory Card Reader	1	1

**Note:**

1. All the model numbers (list on this report) are identical just for marketing purpose only.
2. For different user, the EUT has two different appearances of keyboard (Please refer to external photographs for detail).
3. Client consigns only one model sample (Model number: XO-4 HS) to test. Therefore testing Lab. just guarantees the units, which have been tested.
4. The Adapter Model: BX24-1203 means of "X" (X= U or P) just for marketing purpose only except plug.
5. Client consigns only one sample to test (model number: BU24-1203). Therefore, the testing Lab. just guarantees the unit, which has been tested.
6. The Adapter Model: NA0241WAA and NA0241WEA are identical just for marketing purpose only except plug.
7. Client consigns only one sample to test (model number: NA0241WAA). Therefore, the testing Lab. just guarantees the unit, which has been tested.



### 3 TEST METHODOLOGY

#### 3.1. DECISION OF FINAL TEST MODE

1. The following test mode(s) were scanned during the preliminary test:

Pre-Test Mode								
Mode	CPU	LCD Panel	Memory	EMMC	Camera	WLAN	Battery	Adapter
1	Marvell PXA2128 (1.0GHz)	CHIMEI G075ADE-T01	1GB	4GB	SUYIN CM0316-OLPC01	QMI EM113-MV	BYD CL1	Bestec NA0241WAA
2	Marvell PXA2128 (1.2GHz)	CHIMEI G075ADE-T01	2GB	8GB	SUYIN CM031B-SE01	Liteon WCBN603MH	STL XO-1	Bestec BT-AG250SDF
3	Marvell PXA2128 (1.2GHz)	CHIMEI G075ADE-T01	2GB	8GB	FOXLINK FE03FF-317H	QMI EM113-MV	STL XO-1	Darfon BU24-1203
4	Marvell PXA2128 (1.2GHz)	CHIMEI G075ADE-T01	2GB	8GB	FOXLINK FE03FF-317H	QMI EM113-MV	STL XO-1	Darfon BB0J-C
5	Marvell PXA2128 (1.2GHz)	CHIMEI G075ADE-T01	2GB	8GB	FOXLINK FE03FF-317H	QMI EM113-MV	STL XO-1	Bestec BT-AG250SDF

2. After the preliminary scan, the following test mode was found to produce the highest emission level.

Final Test Mode		
Emission	Conducted Emission	<b>Mode 5 (1200 x 900 Resolution)</b>
	Radiated Emission	<b>Mode 5 (1200 x 900 Resolution)</b>

Then, the above highest emission mode of the configuration of the EUT and cable was chosen for all final test items.

**Remark:** The EUT consumes power from host, which designed with AC power supply of rating 100-240VAC, 50/60Hz. For radiated emission evaluation, 230Vac/50Hz and 120Vac/60Hz had been covered during the pre-test. The worst radiated emission 30MHz ~ 1GHz was found at 230Vac/50Hz and recorded in the applies test report.

#### 3.2. EUT SYSTEM OPERATION

1	Setup the EUT and simulators as shown on 4.2.
2	Turn on the power of all equipment.
3	The module device driver was exercised to play music.
4	Operates the Camera and Wireless LAN functions of EUT.
5	EUT will read data from external hard disk and then writes the data into external hard disk.
6	The EMI (File name: Terminal) test program was loaded from EUT and executed in "Linux" mode.
7	EUT will sends "H" pattern to monitor, the monitor will show "H" pattern on the screen.
8	Repeat the above procedure (3) to (7).

**Note:** Test program is self-repeating throughout the test.



### 4 SETUP OF EQUIPMENT UNDER TEST

#### 4.1. DESCRIPTION OF SUPPORT UNITS

The EUT has been tested as an independent unit together with other necessary accessories or support units. The following support units or accessories were used to form a representative test configuration during the tests.

No.	Equipment	Model No.	Serial No.	FCC ID	Trade Name	Data Cable	Power Cord
1	LCD Monitor	U2410	CN-OJ257M-72872-9 9N-OCTL	FCC DoC	DELL	HDMI Cable: Shielded, 1.8m	Unshielded, 1.8m
2	USB Mouse	M100	N/A	FCC DoC	Logitech	Unshielded, 1.8m	N/A
3	USB 2.0 External HDD	F12-UF	A0100214-43b0015	FCC DoC	TeraSys	Shielded, 1.8m	N/A
4	Multimedia Headset	ClearChat	N/A	FCC DoC	Logitech	Unshielded, 2.0m x2	N/A
5	AP (Remote)	LM-RT210W	12442028770	H8N-RT2 10W	LEMEL	N/A	Unshielded, 1.8m
6	SD Card	WARRANT YVOIOIF REMOVED	N/A	N/A	A-DATA	N/A	N/A

**Note:** Grounding was established in accordance with the manufacturer’s requirements and conditions for the intended use.

#### 4.2. CONFIGURATION OF SYSTEM UNDER TEST

1. LCD Monitor	2. USB Mouse	3. USB 2.0 External HDD
4. Multimedia Headset	5. AP	6. SD Card

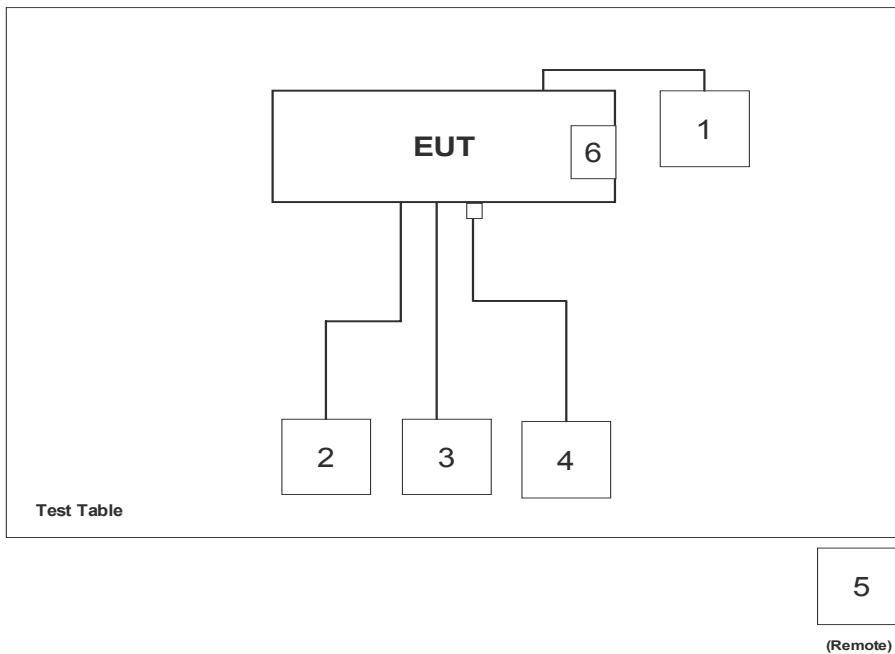





## **5 FACILITIES AND ACCREDITATIONS**

### **5.1. FACILITIES**

All measurement facilities used to collect the measurement data are located at No.81-1, Lane 210, Bade 2nd Rd., Lujhu Township, Taoyuan County 33841, Taiwan, R.O.C.

The sites are constructed in conformance with the requirements of ANSI C63.4 and CISPR Publication 22. All receiving equipment conforms to CISPR 16-1-1, CISPR 16-1-2, CISPR 16-1-3, CISPR 16-1-4, CISPR 16-1-5 and CISPR 16-2-3.

### **5.2. ACCREDITATIONS**

Our laboratories are accredited and approved by the following approval agencies according to ISO/IEC 17025.

<b>Taiwan</b>	TAF
<b>USA</b>	A2LA

The measuring facility of laboratories has been authorized or registered by the following approval agencies.

<b>Canada</b>	Industry Canada
<b>Norway</b>	Nemko
<b>Japan</b>	VCCI
<b>Taiwan</b>	BSMI
<b>USA</b>	FCC

Copies of granted accreditation certificates are available for downloading from our web site, <http://www.ccsrf.com>



### 5.3. MEASUREMENT UNCERTAINTY

Where relevant, the following measurement uncertainty levels have been estimated for tests performed on the EUT as specified in CISPR 16-4-2:

Measurement	Frequency	Uncertainty
Conducted emissions	9kHz~30MHz	±2.3876
Radiated emissions	30~200MHz	±3.7378
	200~1000MHz	±3.7498
	1~8GHz	±4.8572
	8~18GHz	±5.0304
	18~26GHz	±5.3602
	26~40GHz	±5.6294

*This uncertainty represents an expanded uncertainty expressed at approximately the 95% confidence level using a coverage factor of k=2.*

*Consistent with industry standard (e.g. CISPR 22: 2006, clause 11, Measurement Uncertainty) determining compliance with the limits shall be base on the results of the compliance measurement. Consequently the measure emissions being less than the maximum allowed emission result in this be a compliant test or passing test.*

*The acceptable measurement uncertainty value without requiring revision of the compliance statement is base on conducted and radiated emissions being less than  $U_{CISPR}$  which is 3.6dB and 5.2dB respectively. CCS values (called  $U_{Lab}$  in CISPR 16-4-2) is less than  $U_{CISPR}$  as shown in the table above. Therefore, MU need not be considered for compliance.*



## 6 CONDUCTED EMISSION MEASUREMENT

### 6.1. LIMITS OF CONDUCTED EMISSION MEASUREMENT

FREQUENCY (MHz)	Class A (dBuV)		Class B (dBuV)	
	Quasi-peak	Average	Quasi-peak	Average
0.15 - 0.5	79	66	66 - 56	56 - 46
0.50 - 5.0	73	60	56	46
5.0 - 30.0	73	60	60	50

**NOTE:**

- (1) The lower limit shall apply at the transition frequencies.
- (2) The limit decreases in line with the logarithm of the frequency in the range 0.15 to 0.50 MHz.
- (3) All emanations from a class A/B digital device or system, including any network of conductors and apparatus connected thereto, shall not exceed the level of field strengths specified above.

### 6.2. TEST INSTRUMENTS

Conducted Emission Room # 3				
Name of Equipment	Manufacturer	Model	Serial Number	Calibration Due
EMI Test Receiver	R&S	ESCI	101300	09/03/2013
LISN	R&S	ENV216	100069	06/18/2013
LISN	FCC	FCC-LISN-50/250-16 -2-07	06013	11/18/2013
ISN	FCC	FCC-TLISN-T2-02	20587	06/24/2013
ISN	TESEQ	ISN-T8	30842	08/19/2013
Current Probe	FCC	F-35	506	07/01/2013
ISN	FCC	FCC-TLISN-T4-02	20396	07/05/2013
Test S/W	EZ-EMC			

- NOTE:** 1. The calibration interval of the above test instruments is 12 months and the calibrations are traceable to NML/ROC and NIST/USA.  
 2. N.C.R = No Calibration Request.



### **6.3. TEST PROCEDURES** (please refer to measurement standard or CCS SOP PA-031)

#### **Procedure of Preliminary Test**

- The EUT and support equipment, if needed, were set up as per the test configuration to simulate typical usage per the user's manual. When the EUT is a tabletop system, a wooden table with a height of 0.8 meters is used and is placed on the ground plane as per ANSI C63.4 (see Test Facility for the dimensions of the ground plane used). When the EUT is a floor standing equipment, it is placed on the ground plane, which has a 12 mm non-conductive covering to insulate the EUT from the ground plane.
- All I/O cables were positioned to simulate typical actual usage as per ANSI C63.4.
- The test equipment EUT installed by AC main power, through a Line Impedance Stabilization Network (LISN), which was supplied power source and was grounded to the ground plane.
- All support equipment power by from a second LISN.
- The test program of the EUT was started. Emissions were measured on each current carrying line of the EUT using an EMI Test Receiver connected to the LISN powering the EUT.
- The Receiver scanned from 150kHz to 30MHz for emissions in each of the test modes.
- During the above scans, the emissions were maximized by cable manipulation.
- The test mode(s) described in Item 3.1 were scanned during the preliminary test.
- After the preliminary scan, we found the test mode described in Item 3.1 producing the highest emission level.
- The worst configuration of EUT and cable of the above highest emission level were recorded for reference of the final test.

#### **Procedure of Final Test**

- EUT and support equipment were set up on the test bench as per the configuration with highest emission level in the preliminary test.
- A scan was taken on both power lines, Line 1 and Line 2, recording at least the six highest emissions. Emission frequency and amplitude were recorded into a computer in which correction factors were used to calculate the emission level and compare reading to the applicable limit.
- The test data of the worst-case condition(s) was recorded.

**6.4. TEST SETUP**

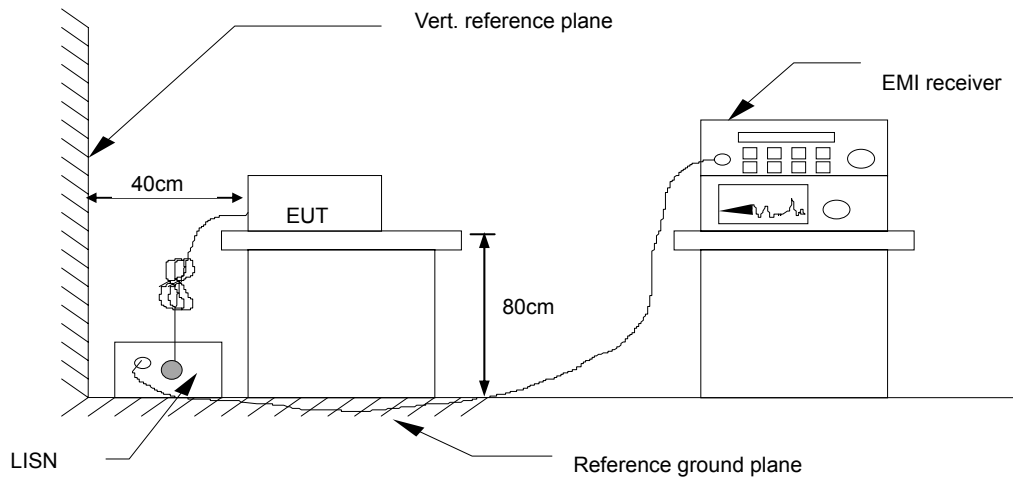

- For the actual test configuration, please refer to the related item – Photographs of the Test Configuration.

**6.5. DATA SAMPLE:**

Frequency (MHz)	QuasiPeak reading (dBuV)	Average reading (dBuV)	Correction factor (dB)	QuasiPeak result (dBuV)	Average result (dBuV)	QuasiPeak limit (dBuV)	Average limit (dBuV)	QuasiPeak margin (dB)	Average margin (dB)	Remark
x.xx	43.95	33.00	10.00	53.95	43.00	56.00	46.00	-2.05	-3.00	Pass

Frequency (MHz) = Emission frequency in MHz  
 Reading (dBuV) = Uncorrected Analyzer/Receiver reading + Insertion loss of LISN, if it > 0.5 dB  
 Correction Factor (dB) = LISN Factor + Cable Loss  
 Result (dBuV) = Raw reading converted to dBuV and CF added  
 Limit (dBuV) = Limit stated in standard  
 Margin (dB) = Result (dBuV) – Limit (dBuV)



6.6. TEST RESULTS

<b>Model No.</b>	XO-4 HS	<b>6dB Bandwidth</b>	9 kHz
<b>Environmental Conditions</b>	25°C, 57% RH	<b>Test Mode</b>	Mode 5
<b>Tested by</b>	Chieh Cheng	<b>Line</b>	L1
<b>Standard</b>	FCC Class B Limit		

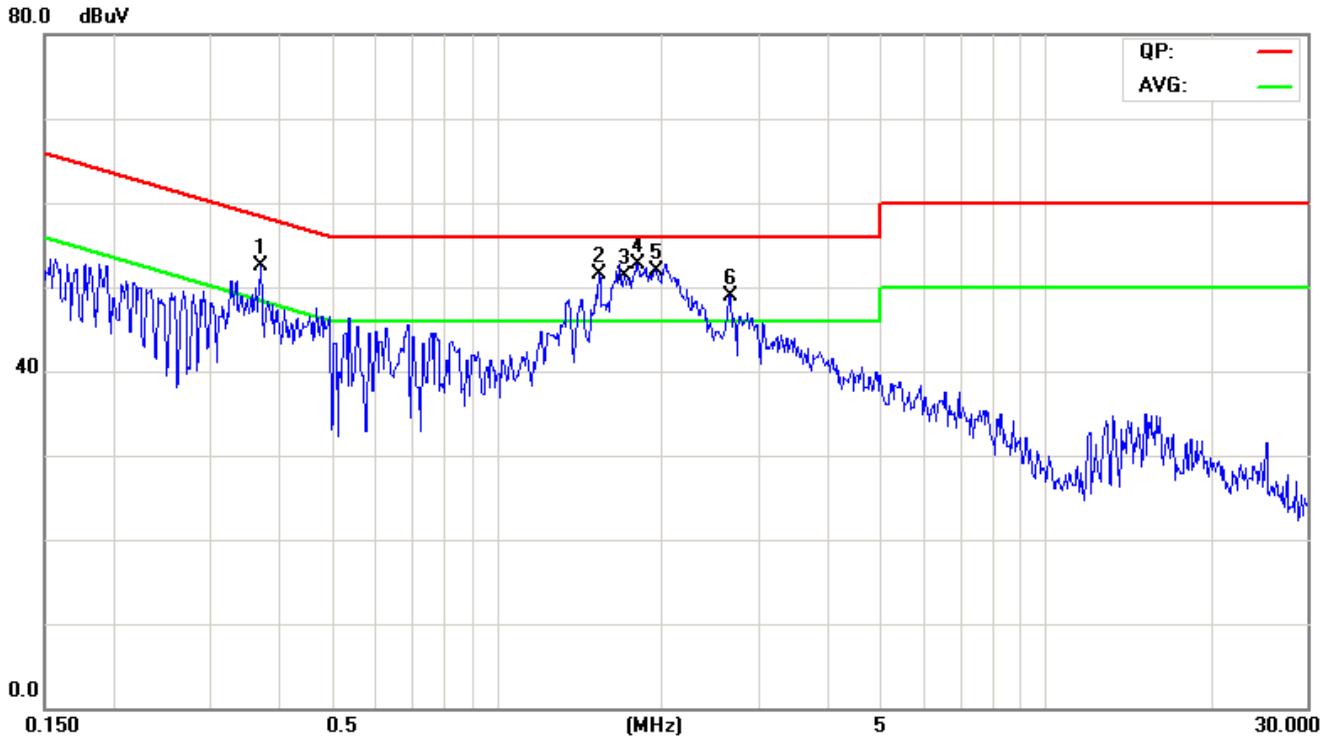

NO.	Frequency	QuasiPeak reading	Average reading	Correction factor	QuasiPeak result	Average result	QuasiPeak limit	Average limit	QuasiPeak margin	Average margin	Remark
	(MHz)	(dBuV)	(dBuV)	(dB)	(dBuV)	(dBuV)	(dBuV)	(dBuV)	(dB)	(dB)	(Pass/Fail)
1	0.3665	31.84	14.59	9.68	41.52	24.27	58.58	48.58	-17.06	-24.31	Pass
2	1.5384	32.76	19.83	9.77	42.53	29.60	56.00	46.00	-13.47	-16.40	Pass
3	1.6900	34.99	22.43	9.77	44.76	32.20	56.00	46.00	-11.24	-13.80	Pass
4	1.8211	37.09	23.55	9.78	46.87	33.33	56.00	46.00	-9.13	-12.67	Pass
5*	1.9374	37.95	25.50	9.78	47.73	35.28	56.00	46.00	-8.27	-10.72	Pass
6	2.6545	28.78	17.16	9.80	38.58	26.96	56.00	46.00	-17.42	-19.04	Pass

REMARKS: L1 = Line One (Live Line)



<b>Model No.</b>	XO-4 HS	<b>6dB Bandwidth</b>	9 kHz
<b>Environmental Conditions</b>	25°C, 57% RH	<b>Test Mode</b>	Mode 5
<b>Tested by</b>	Chieh Cheng	<b>Line</b>	L2
<b>Standard</b>	FCC Class B Limit		

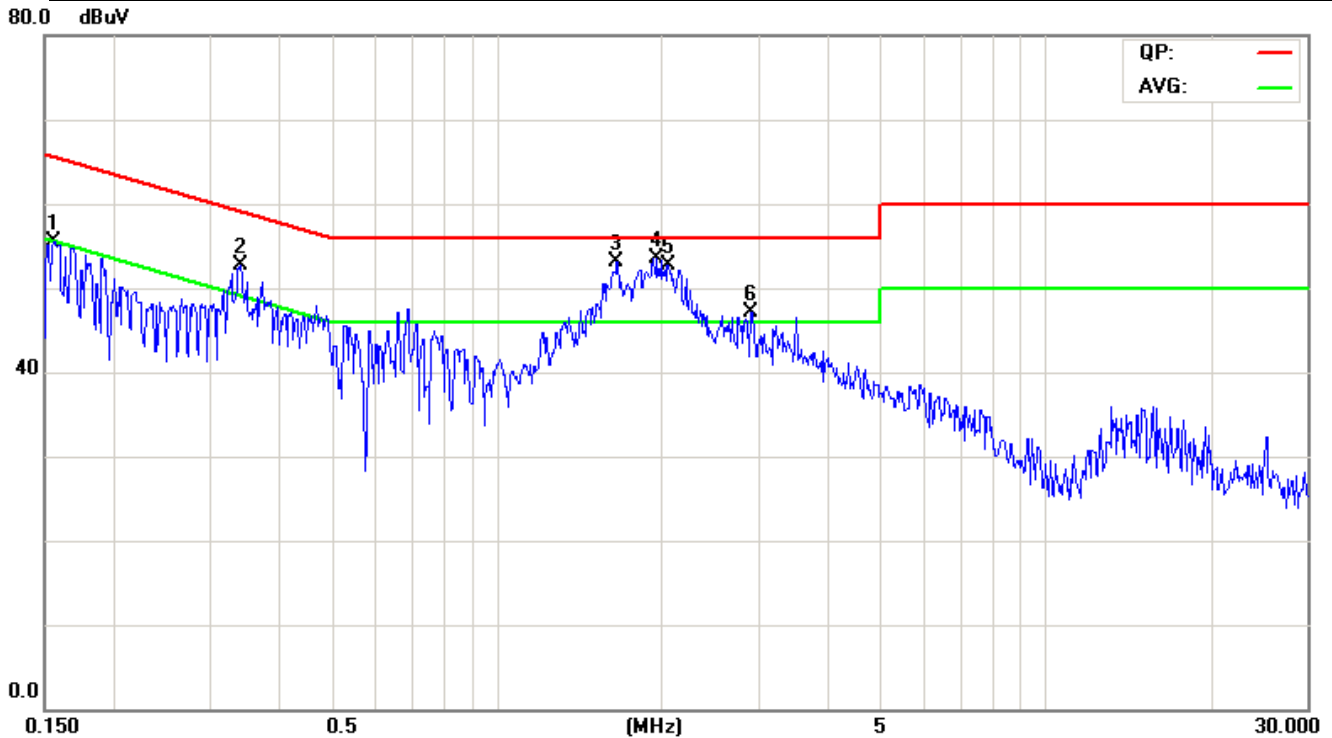

NO.	Frequency (MHz)	QuasiPeak reading (dBuV)	Average reading (dBuV)	Correction factor (dB)	QuasiPeak result (dBuV)	Average result (dBuV)	QuasiPeak limit (dBuV)	Average limit (dBuV)	QuasiPeak margin (dB)	Average margin (dB)	Remark (Pass/Fail)
1	0.1566	37.53	17.68	9.66	47.19	27.34	65.64	55.64	-18.45	-28.30	Pass
2	0.3368	36.20	30.02	9.67	45.87	39.69	59.28	49.28	-13.41	-9.59	Pass
3	1.6648	34.81	22.91	9.75	44.56	32.66	56.00	46.00	-11.44	-13.34	Pass
4*	1.9715	37.40	24.29	9.76	47.16	34.05	56.00	46.00	-8.84	-11.95	Pass
5	2.0725	36.08	23.60	9.76	45.84	33.36	56.00	46.00	-10.16	-12.64	Pass
6	2.8860	27.15	15.52	9.79	36.94	25.31	56.00	46.00	-19.06	-20.69	Pass

**REMARKS:** L2 = Line Two (Neutral Line)



## 7 RADIATED EMISSION MEASUREMENT

### 7.1. LIMITS OF RADIATED EMISSION MEASUREMENT

Below 1GHz (for digital device)

FREQUENCY (MHz)	dBuV/m (At 10m)	
	Class A	Class B
30 ~ 230	40	30
230 ~ 1000	47	37

Below 1GHz (for non-digital device)

Class A Radiated Emission limit at 10m (for others)

Frequency (MHZ)	Field Strength Limit (uV/m)Q.P.	Field Strength Limit (dBuV/m)Q.P.
30 - 88	90	39
88 - 216	150	43.5
216 – 960	210	46.4
Above 960	300	49.5

Class B Radiated Emission limit at 3m (for others)

Frequency (MHZ)	Field Strength Limit (uV/m)Q.P.	Field Strength Limit (dBuV/m)Q.P.
30 - 88	100	40
88 - 216	150	43.5
216 – 960	200	46
Above 960	500	54

Above 1GHz (for all device)

Frequency (MHZ)	Class A (dBuV/m) (At 10m)		Class B (dBuV/m) (At 3m)	
	Average	Peak	Average	Peak
Above 1000	49.5	69.5	54	74

- NOTE:** 1. The lower limit shall apply at the transition frequencies.  
 2. Emission level (dBuV/m) = 20 log Emission level (uV/m).  
 3. The measurement above 1GHz is at close-in distances 3m, and determine the limit **L2** corresponding to the close-in distance **d2** by applying the following relation:  $L2 = L1 (d1/d2)$ , where **L1** is the specified limit in microvolts per metre (uV/m) at the distance **d1 (10m)**, **L2** is the new limit for distance **d2 (3m)**.  
 So the new Class A limit above 1GHz at 3m is as following table:

Frequency (MHZ)	Class A (dBuV/m) (At 3m)	
	Average	Peak
Above 1000	60	80





According to FCC Part 15.33 (b), for an unintentional radiator, including a digital device, the spectrum shall be investigated from the lowest radio frequency signal generated or used in the device, without going below the lowest frequency for which a radiated emission limit is specified, up to the frequency shown in the following table:

<b>Highest frequency generated or used in the device or in which the device operated or tunes (MHz)</b>	<b>Upper frequency of measurement range (MHz)</b>
Below 1.705	30
1.705-108	1000
108-500	2000
500-1000	5000
Above 1000	5 <sup>th</sup> harmonic of the highest frequency or 40GHz, whichever is lower



**7.2. TEST INSTRUMENTS**

<b>Open Area Test Site # 2</b>				
<b>Name of Equipment</b>	<b>Manufacturer</b>	<b>Model</b>	<b>Serial Number</b>	<b>Calibration Due</b>
Spectrum Analyzer	Agilent	E4411B	US41062825	08/19/2013
EMI Test Receiver	R&S	ESCS30	847793/012	05/31/2013
Pre-Amplifier	Agilent	8447D	2944A08780	04/17/2013
Bilog Antenna	CHASE	CBL6112A	2307	09/30/2013
Turn Table	Chance Most	CM-T003-1	T807-6	N.C.R
Antenna Tower	Chance Most	CM-A003-1	A807-6	N.C.R
Controller	CCS	CC-C-1F	N/A	N.C.R
RF Switch	Anritsu	MP59B	10953	N.C.R
Test S/W	EZ-EMC			

<b>3 Meter Chamber</b>				
<b>Name of Equipment</b>	<b>Manufacturer</b>	<b>Model</b>	<b>Serial Number</b>	<b>Calibration Due</b>
Spectrum Analyzer	Agilent	E4446A	MY48250064	01/13/2014
Pre-Amplifier	HP	8449B	3008A00965	04/17/2013
Pre-Amplifier	MITEQ	AMF-6F-260400-40-8P	985646	05/20/2013
Horn Antenna	EMCO	3115	9602-4659	06/14/2013
Horn Antenna	EMCO	3116	00026370	10/07/2013
Low Loss Cable	Huber+Suhner	104PEA	24815/4PEA	08/08/2013
Low Loss Cable	Huber+Suhner	104PEA	30956/4PEA	04/16/2013
Turn Table	CCS	CC-T-1F	N/A	N.C.R
Antenna Tower	CCS	CC-A-1F	N/A	N.C.R
Controller	CCS	CC-C-1F	N/A	N.C.R
Bore-Sight Antenna Tower	CCS	CCS-BORESIGHT	001	N.C.R
Test S/W	EZ-EMC			

**NOTE:** 1. The calibration interval of the above test instruments is 12 months and the calibrations are traceable to NML/ROC and NIST/USA.  
 2. N.C.R = No Calibration Request.



### **7.3. TEST PROCEDURES** (please refer to measurement standard or CCS SOP PA-031)

#### **Procedure of Preliminary Test**

- The equipment was set up as per the test configuration to simulate typical usage per the user's manual. When the EUT is a tabletop system, a wooden turntable with a height of 0.8 meters is used which is placed on the ground plane. When the EUT is a floor standing equipment, it is placed on the ground plane which has a 3-12 mm non-conductive covering to insulate the EUT from the ground plane.
- Support equipment, if needed, was placed as per ANSI C63.4.
- All I/O cables were positioned to simulate typical usage as per ANSI C63.4.
- The EUT received AC power source from the outlet socket under the turntable. All support equipment power received from another socket under the turntable.
- The antenna was placed at 3 or 10 meter away from the EUT as stated in ANSI C63.4. The antenna connected to the Spectrum Analyzer via a cable and at times a pre-amplifier would be used.
- The Analyzer / Receiver quickly scanned from 30MHz to 40GHz. The EUT test program was started. Emissions were scanned and measured rotating the EUT to 360 degrees and positioning the antenna 1 to 4 meters above the ground plane, in both the vertical and the horizontal polarization, to maximize the emission reading level (For Below 1GHz) and keeping the antenna in the 'cone of radiation' from that area and pointed at the area both in azimuth and elevation, with polarization oriented for maximum response (For Above 1GHz).
- The test mode(s) described in Item 3.1 were scanned during the preliminary test:
- After the preliminary scan, we found the test mode described in Item 3.1 producing the highest emission level.
- The worst configuration of EUT and cable of the above highest emission level were recorded for reference of the final test.

#### **Procedure of Final Test**

- EUT and support equipment were set up on the turntable as per the configuration with highest emission level in the preliminary test.
- The Analyzer / Receiver scanned from 30MHz to 40GHz. Emissions were scanned and measured rotating the EUT to 360 degrees, varying cable placement and positioning the antenna 1 or 1 to 4 meters above the ground plane, in both the vertical and the horizontal polarization, to maximize the emission reading level.
- Recording at least the six highest emissions. Emission frequency, amplitude, antenna position, polarization and turntable position were recorded into a computer in which correction factors were used to calculate the emission level and compare reading to the applicable limit and Q.P. (For Below 1GHz) or Peak/Average (For Above 1GHz) reading is presented.
- The test data of the worst-case condition(s) was recorded.

### 7.4. TEST SETUP

Below 1GHz

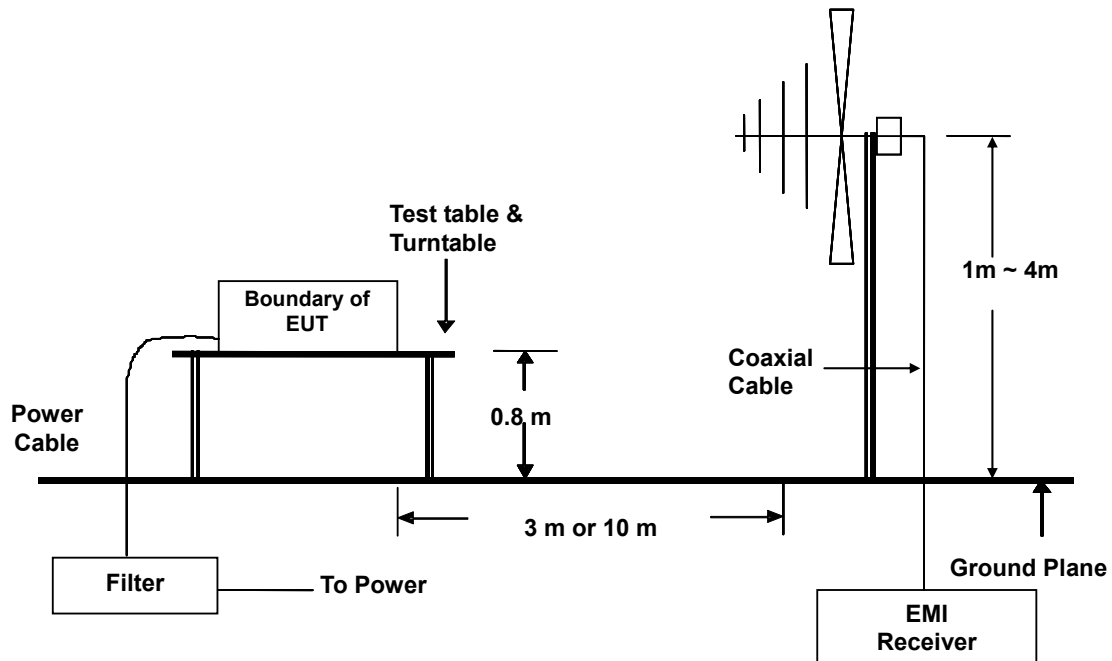

Above 1GHz

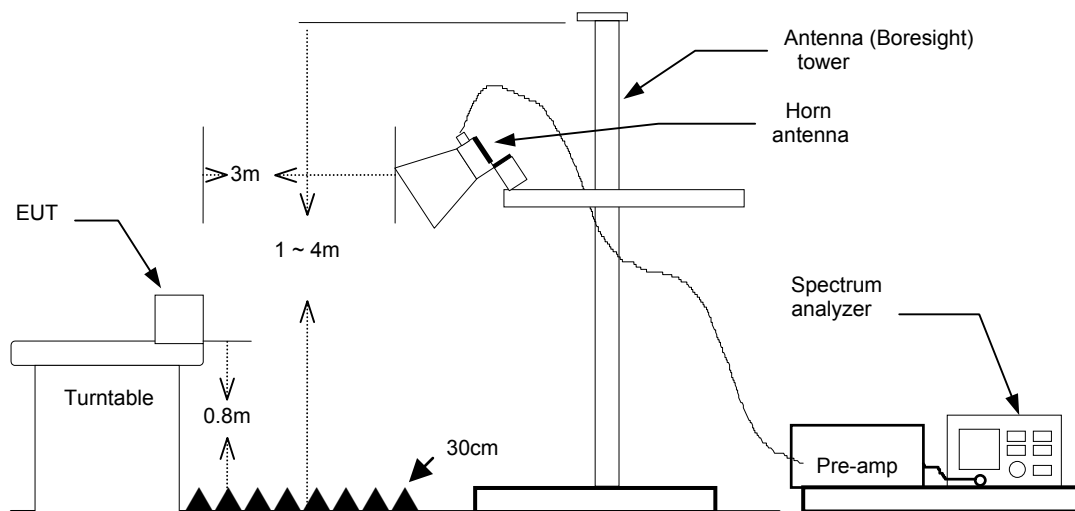

- For the actual test configuration, please refer to the related item – Photographs of the Test Configuration.



**7.5. DATA SAMPLE:**

**Below 1GHz**

Frequency (MHz)	Reading (dBuV)	Correction Factor (dB/m)	Result (dBuV/m)	Limit (dBuV/m)	Margin (dB)	Degree ( ° )	Height (cm)	Remark
xx.xx	16.49	9.86	26.35	30.00	-3.65	116.00	101.00	QP

**Above 1GHz**

Frequency (MHz)	Reading (dBuV/m)	Correct Factor(dB)	Result (dBuV/m)	Limit (dBuV/m)	Margin (dB)	Height (cm)	Degree ( ° )	Remark
XX	54.08	-11.80	42.28	74.00	-27.72	100	185	peak
XX	34.80	-11.80	23.00	54.00	-27.00	100	185	AVG

- Frequency (MHz) = Emission frequency in MHz
- Reading (dBuV) = Uncorrected Analyzer / Receiver reading
- Correction Factor (dB/m) = Antenna factor + Cable loss – Amplifier gain
- Result (dBuV/m) = Reading (dBuV) + Corr. Factor (dB/m)
- Limit (dBuV/m) = Limit stated in standard
- Margin (dB) = Result (dBuV/m) – Limit (dBuV/m)
- Q.P. = Quasi-Peak



### 7.6. TEST RESULTS

Below 1GHz

<b>Model No.</b>	XO-4 HS	<b>Test Mode</b>	Mode 5
<b>Environmental Conditions</b>	26°C, 60% RH	<b>6dB Bandwidth</b>	120 kHz
<b>Antenna Pole</b>	Vertical	<b>Antenna Distance</b>	10m
<b>Detector Function</b>	Quasi-peak.	<b>Tested by</b>	Nelson Tsai
<b>Standard</b>	FCC Class B with CISPR 22 Class B Limit		

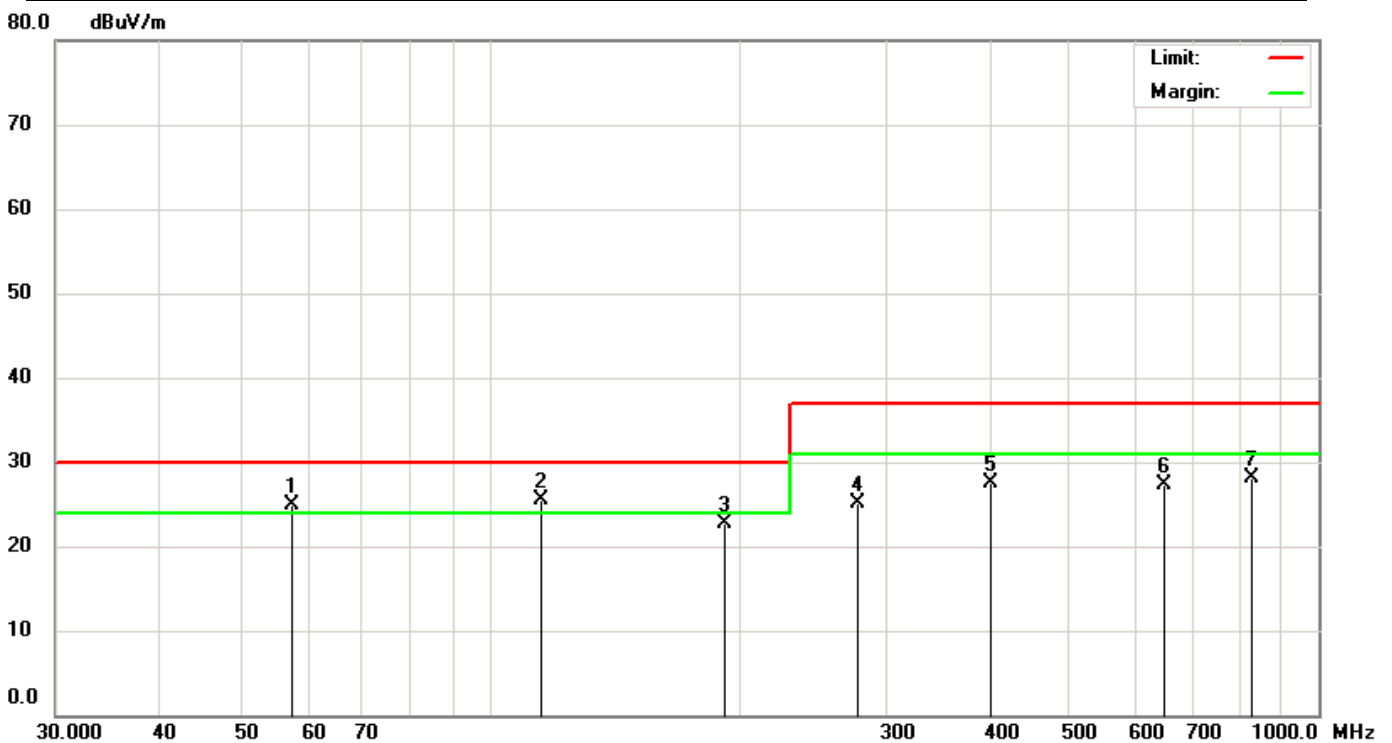

No.	Frequency (MHz)	Reading (dBuV/m)	Correct (dB/m)	Result (dBuV/m)	Limit (dBuV/m)	Margin (dB)	Height (cm)	Degree (°)	Remark
1	57.7000	44.33	-19.36	24.97	30.00	-5.03	100	227	QP
2	114.7200	38.90	-13.44	25.46	30.00	-4.54	100	360	QP
3	192.3000	37.90	-15.19	22.71	30.00	-7.29	100	47	QP
4	277.0000	35.43	-10.39	25.04	37.00	-11.96	100	304	QP
5	401.5000	35.68	-8.12	27.56	37.00	-9.44	289	268	QP
6	648.0000	31.07	-3.71	27.36	37.00	-9.64	260	336	QP
7	831.0000	29.36	-1.16	28.20	37.00	-8.80	184	63	QP

**REMARKS:** 1. 30MHz to 1000MHz test is Applicable CISPR 22 standard.  
2. The other emission levels were very low against the limit.



<b>Model No.</b>	XO-4 HS	<b>Test Mode</b>	Mode 5
<b>Environmental Conditions</b>	26°C, 60% RH	<b>6dB Bandwidth</b>	120 kHz
<b>Antenna Pole</b>	Horizontal	<b>Antenna Distance</b>	10m
<b>Detector Function</b>	Quasi-peak.	<b>Tested by</b>	Nelson Tsai
<b>Standard</b>	FCC Class B with CISPR 22 Class B Limit		

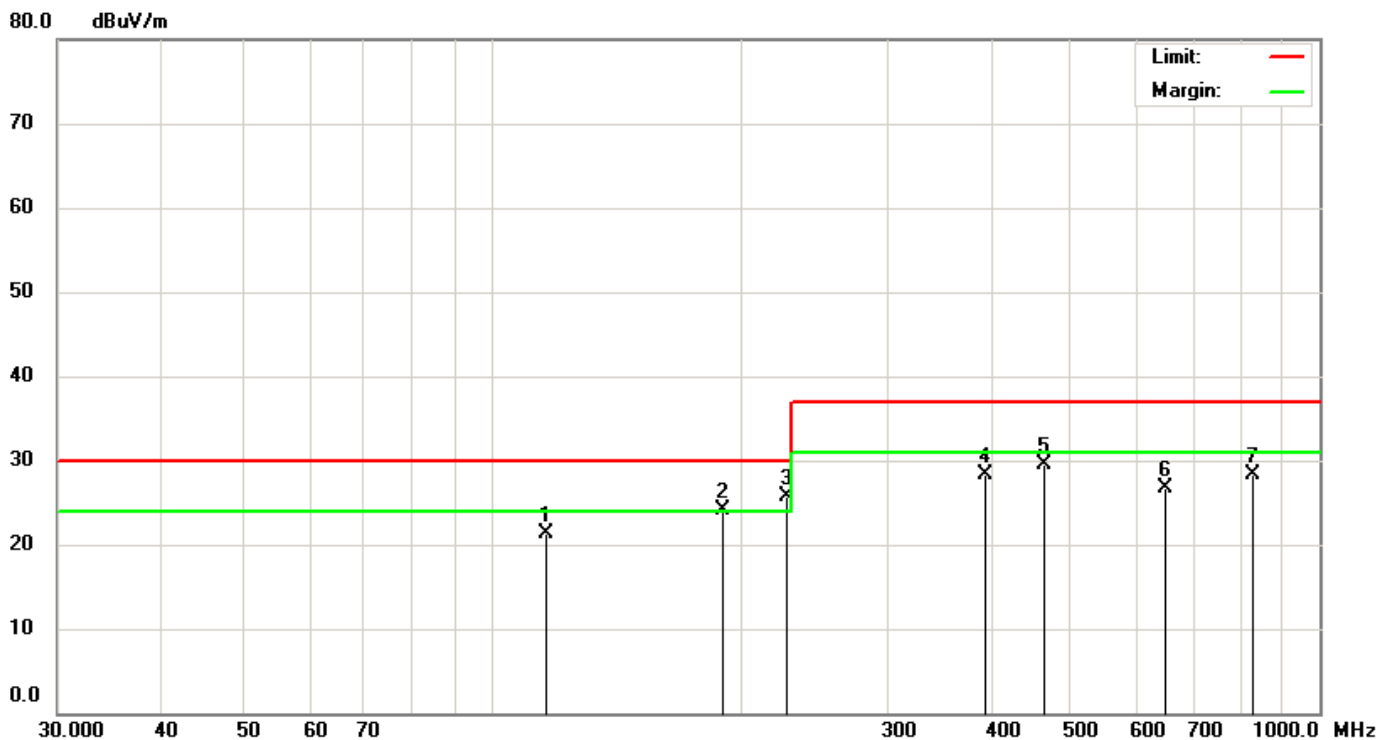

No.	Frequency (MHz)	Reading (dBuV/m)	Correct (dB/m)	Result (dBuV/m)	Limit (dBuV/m)	Margin (dB)	Height (cm)	Degree (°)	Remark
1	115.8000	34.70	-13.36	21.34	30.00	-8.66	356	129	QP
2	190.6000	39.30	-15.21	24.09	30.00	-5.91	341	142	QP
3	227.0000	39.40	-13.73	25.67	30.00	-4.33	291	93	QP
4	393.5000	36.69	-8.29	28.40	37.00	-8.60	312	105	QP
5	464.5000	36.45	-7.03	29.42	37.00	-7.58	296	6	QP
6	648.0000	30.38	-3.71	26.67	37.00	-10.33	174	359	QP
7	831.0000	29.53	-1.16	28.37	37.00	-8.63	100	49	QP

**REMARKS:**

- 30MHz to 1000MHz test is Applicable CISPR 22 standard.
- The other emission levels were very low against the limit.



Above 1GHz

<b>Model No.</b>	XO-4 HS	<b>Test Mode</b>	Mode 5
<b>Environmental Conditions</b>	26°C, 56% RH	<b>Upper frequency</b>	6000MHz
<b>Antenna Pole</b>	Vertical	<b>Antenna Distance</b>	3m
<b>Highest frequency generated or used</b>	1.2GHz	<b>6dB Bandwidth</b>	1 MHz
<b>Detector Function:</b>	Peak/Average	<b>Tested By</b>	Aj Huang
<b>Standard</b>	FCC Class B Limit		

No.	Frequency (MHz)	Reading (dBuV/m)	Correct dB/m	Result (dBuV/m)	Limit (dBuV/m)	Margin (dB)	Height (cm)	Degree ( ° )	Remark
1	1610.000	67.77	-21.17	46.60	74.00	-27.40	106	300	peak
2	2410.000	65.65	-18.04	47.61	74.00	-26.39	121	170	peak
3	3895.000	62.05	-12.14	49.91	74.00	-24.09	124	137	peak
4	5435.000	58.94	-8.97	49.97	74.00	-24.03	119	208	peak
5	5705.000	59.08	-8.52	50.56	74.00	-23.44	140	186	peak
6	5830.000	58.99	-8.43	50.56	74.00	-23.44	137	88	peak

- REMARKS:**
1. The other emission levels were very low against the limit.
  2. "--", means the average measurement was not performed when the measured peak data under the limit of average detection.





<b>Model No.</b>	XO-4 HS	<b>Test Mode</b>	Mode 5
<b>Environmental Conditions</b>	26°C, 56% RH	<b>Upper frequency</b>	6000MHz
<b>Antenna Pole</b>	Horizontal	<b>Antenna Distance</b>	3m
<b>Highest frequency generated or used</b>	1.2GHz	<b>6dB Bandwidth</b>	1 MHz
<b>Detector Function:</b>	Peak/Average	<b>Tested By</b>	Aj Huang
<b>Standard</b>	FCC Class B Limit		

No.	Frequency (MHz)	Reading (dBuV/m)	Correct dB/m	Result (dBuV/m)	Limit (dBuV/m)	Margin (dB)	Height (cm)	Degree ( ° )	Remark
1	2135.000	69.54	-18.81	50.73	74.00	-23.27	114	219	peak
2	3775.000	62.05	-12.54	49.51	74.00	-24.49	106	359	peak
3	3940.000	61.63	-11.98	49.65	74.00	-24.35	128	202	peak
4	5315.000	59.81	-9.46	50.35	74.00	-23.65	141	305	peak
5	5685.000	59.07	-8.54	50.53	74.00	-23.47	125	316	peak
6	5760.000	58.88	-8.49	50.39	74.00	-23.61	103	170	peak

- REMARKS:**
1. The other emission levels were very low against the limit.
  2. "--", means the average measurement was not performed when the measured peak data under the limit of average detection.



## 8 PHOTOGRAPHS OF THE TEST CONFIGURATION

### CONDUCTED EMISSION TEST





**RADIATED EMISSION TEST**

**Below 1GHz**







Above 1GHz

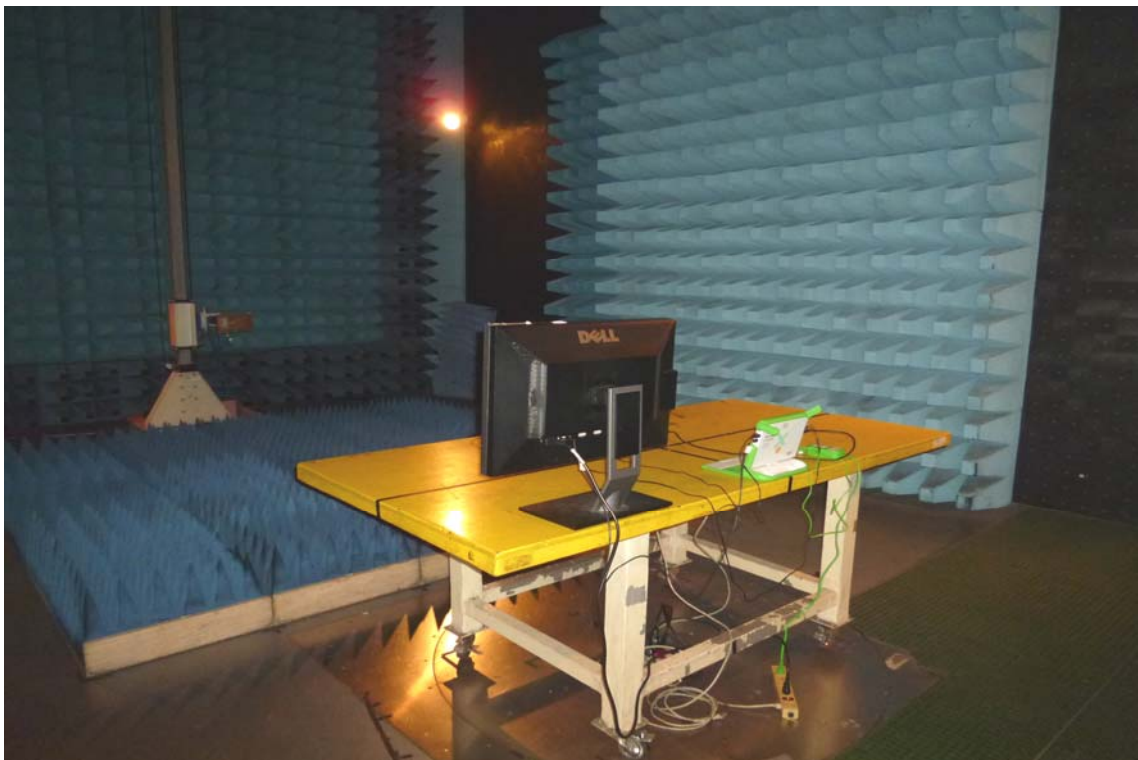



---

**APPENDIX 1: PHOTOGRAPHS OF EUT**

**Refer to T130222L03 External Photographs.**