



# CE EMC TEST REPORT

For

## Laptop Computer

**Brand Name:** OLPC  
**Model NO.:** XO-4 HS / XO-4 / XO-4 HS Touch / XO-4 Touch  
**Report NO.:** 20130222-1  
**Issued Date:** Feb. 22, 2013  
**Issued By:** Compliance Laboratory of Tech-Front (Shanghai) Computer Co., Ltd  
**Lab Address:** No. 68, Sanzhuang Road, Songjiang Export Processing Zone, Shanghai, P. R. China  
**Tel:** +86-21-3781-8168  
**Fax:** +86-21-6774-7135

The test result relate only to the samples tested. The test report shall not be reproduced except in full without the written approval of our laboratory. This report must not be used to claim product endorsement by CNAS or any agency of the Government. The test results shown in the test report are traceable to the national/international standard through the calibration of the equipment and evaluated measurement uncertainty herein.



# Test Report Certification

**Applicant:** Quanta Computer Inc  
**Manufacturer:** Quanta Computer Inc  
**Product:** Laptop Computer  
**Brand Name:** OLPC  
**Model Number:** XO-4 HS / XO-4 / XO-4 HS Touch / XO-4 Touch  
**Tested Voltage:** 230V<sub>AC</sub>, 50Hz  
**Tested Date:** Jan. 09-Jan. 13, 2013

**Applicable Standards:**

**Emission:** EN 55022: 2010, Class B  
 EN 61000-3-2: 2009, Class D  
 EN 61000-3-3:2008

**Immunity:** EN 55024:2010  
 EN 61000-4-2:2009  
 EN61000-4-3:2006+A2:2010  
 EN61000-4-4:2004+A1:2010  
 EN 61000-4-5:2006  
 EN 61000-4-6:2009  
 EN 61000-4-8:2010  
 EN 61000-4-11:2004

<b>Test Result</b>	No non-compliance noted
--------------------	-------------------------

The above equipment has been tested by Compliance Laboratory of Tech-Front (Shanghai) Computer Co., Ltd. , and found compliance with the requirements set forth in the Electromagnetic Compatibility Directive 2004/108/EC and technical standards mentioned above. The result of testing in this report apply only to the product/system, which was tested. Other similar equipment will not necessarily produce the same results due to production tolerance and measurement uncertainties.

Approved By

Reviewed By

Herculius Hsu/ EMC manager:

Bill Bo/ Senior engineer



**Section 1: General Information**..... 6

    1.1 Test result summary .....6

    1.2 Introduction .....7

    1.3 Test Procedure .....8

**Section 2: Test Facility and Procedure**.....9

    2.1 Test Facility used for Emission Testing ..... 9

        2.1.1 Measurement Uncertainty ..... 9

        2.1.2 Lab Accreditation .....10

        2.1.3 Software to exercise EUT .....10

        2.1.4 Special Accessories .....10

        2.1.5 Equipment Modifications and Deviations .....10

        2.1.6 Test Configuration .....11

            - Arrangement block diagram ..... 11

            - Associated equipment ..... 11

            - Pre-test configuration .....13

            - Worst case for final testing ..... 13

        2.1.7 Cable Description and Information .....13

    2.2 Measurement Equipment ..... 14

        2.2.1 Conducted Emissions .....14

        2.2.2 Radiated Emissions .....14

        2.2.3 Power Harmonic / Flickers .....15

        2.2.4 Electrostatic Discharge (ESD) Immunity .....15

        2.2.5 Radiated Electromagnetic Field Immunity .....15

        2.2.6 Fast Transient / Burst Immunity .....16

        2.2.7 Surge Immunity .....16

        2.2.8 Conducted Disturbance / Induced Radio-Frequency Field Immunity ...16

        2.2.9 Power Frequency Magnetic Field Immunity .....17

        2.2.10 Voltage Dips / Short Interruptions and Interruptions .....17



- Section 3: Electromagnetic Emissions Test**..... 18
  - 3.1 Emission ..... 18
    - 3.1.1 Line Conducted Emissions Test ..... 18
      - Measurement Procedures Utilized for Conducted Emissions ..... 18
      - Limits ..... 19
      - Test setup..... 20
      - Conducted Emissions Test Data ..... 21
    - 3.1.2 Radiated Emissions Test ..... 23
      - Measurement Procedures Utilized for Radiated Emissions ..... 23
      - Limits ..... 24
      - Test setup..... 24
      - Radiated Emissions Test Data ..... 26
    - 3.1.3 Power Harmonics Measurement ..... 30
      - Measurement Procedures Utilized for Harmonics..... 30
      - Test setup..... 31
      - Test Condition..... 31
      - Test results..... 31
    - 3.1.4 Power Voltage Fluctuation / Flicker Measurement .....32
      - Measurement Procedures Utilized for Flicker..... 32
      - Test setup..... 32
      - Test Condition..... 33
      - Test results..... 33
  - 3.2 Electromagnetic Immunity Report .....34
    - 3.2.1 Electrostatic Discharge (ESD) Immunity Test .....36
      - Measurement Procedures Utilized for ESD..... 36
      - Test setup..... 37
      - Test Condition..... 37
      - Test results..... 38
    - 3.2.2 Radiated Electromagnetic Field Immunity Test .....39
      - Measurement Procedures Utilized for RS..... 39
      - Test setup..... 39
      - Test Condition..... 40
      - Test results..... 40
    - 3.2.3 Fast Transient/Burst Immunity Test.....41
      - Measurement Procedures Utilized for EFT..... 41
      - Test setup..... 41
      - Test Condition..... 42
      - Test results..... 42



- 3.2.4 Surge Immunity Test ..... 43
  - Measurement Procedures Utilized for Surge..... 43
  - Test setup..... 43
  - Test Condition..... 44
  - Test results..... 44
- 3.2.5 Conducted Disturbance / Induced Radio-Frequency Field Immunity Test
  - Measurement Procedures Utilized for CS..... 45
  - Test setup..... 45
  - Test Condition..... 46
  - Test results..... 46
- 3.2.6 Power Frequency Magnetic Field Immunity Test ..... 47
  - Measurement Procedures Utilized for PFMF..... 47
  - Test setup..... 47
  - Test Condition..... 48
  - Test results..... 48
- 3.2.7 Voltage Dips / Short Interruptions and Interruptions Test ..... 49
  - Measurement Procedures Utilized for Dips..... 49
  - Test setup..... 49
  - Test Condition..... 50
  - Test results..... 50
- Section 4: Test Arrangement Photos.....51**
  - 4.1 Conducted Emissions .....51
  - 4.2 Radiated Emissions .....52
  - 4.3 Power Harmonics and Flick Measurement ..... 54
  - 4.4 Electrostatic Discharge (ESD)..... 55
  - 4.5 Radiated Electromagnetic Field Immunity..... 58
  - 4.6 Fast Transient / Burst Immunity.....58
  - 4.7 Surge Immunity..... 59
  - 4.8 Conducted Disturbance, Induced Radio-Frequency Field Immunity.....59
  - 4.9 Power Frequency Magnetic Field Immunity Test ..... 60
  - 4.10 Voltage Dips / Short Interruptions and Interruptions..... 60



## Section 1: General Information

### 1.1 Test Result summary

Emission			
Standard	Item	Result	Remarks
EN 55022: 2010	Conducted (Main Port)	PASS	Meet Class B limit
	Conducted (Telecom port)	PASS	Meet Class B limit
	Radiated	PASS	Meet Class B limit
EN 61000-3-2: 2009	Harmonic current emissions	PASS	NA
EN 61000-3-3:2008	Voltage fluctuations & flicker	PASS	Meets the requirements

Immunity 【EN 55024:2010】			
Standard	Item	Result	Remarks
EN 61000-4-2: 2009	ESD	PASS	Meets the requirements of Performance Criterion B
EN61000-4-3:2006+A2:2010	RS	PASS	Meets the requirements of Performance Criterion A
EN61000-4-4:2004+A1:2010	EFT	PASS	Meets the requirements of Performance Criterion B
EN 61000-4-5: 2006	Surge	PASS	Meets the requirements of Performance Criterion B
EN 61000-4-6: 2009	CS	PASS	Meets the requirements of Performance Criterion A
EN 61000-4-8:2010	PFMF	PASS	Meets the requirements of Performance Criterion A
EN 61000-4-11: 2004	Voltage dips & voltage variations	PASS	<p><b>Meets the requirements of Voltage Dips:</b></p> <p>1) &gt;95% reduction Performance Criterion B</p> <p>2) 30% reduction Performance Criterion C</p> <p><b>Voltage Interruptions:</b></p> <p>1) &gt;95% reduction Performance Criterion C.</p>

- Note:** 1) The test result judgment is decided by the limit of test standard  
 2) The information of measurement uncertainty is available upon the customer's request.



## 1.2 Introduction

Product	Laptop Computer		
Trade Name	OLPC		
Model Name	XO-4 HS / XO-4 / XO-4 HS Touch / XO-4 Touch		
Housing Type	Plastic		
AC Power Adapter	Bestec	Model	NA0241WAA
			BT-AG250SDF
	Darfon	Model	BU24-1203
			BB0J-C
			BP24-1203
AC Power Adapter Rating	I/P: 100-240Vac O/P: 13.5Vdc,1.85A/12Vdc,2A		
AC Power Cord Type	Non-shielded AC 2pin (0.9m)		
DC Power Cable Type	Non-shielded DC (1.5m) /Non-shielded DC (1.8m)		
EMMC	4GB / 8GB		
Memory Capacity	1GB / 2GB		
CPU	Marvell	Model	PXA2128 (1.0GHz)
			PXA2128 (1.2GHz)
7.5" LCD Panel	CHIMEI	Model	G075ADE-T01
Camera	SUYIN	Model	CM0316-OLPC01
			CM031B-SE01
	FOXLINK	Model	FE03FF-317H
WLAN	QMI	Model	EM113-MV
	Liteon	Model	WCBN603MH
Battery	BYD	Model	CL1
	STL	Model	XO-1



I/O Port:

I/O Port Types	Quantity
Audio in port	1
Audio out port	1
USB port	2
HDMI port	1
SD Card port	1



### 1.3 Test Procedure

The EUT was tested using special test software called H patterns, which exercises all external I/O ports as well as the internal storage media by writing and reading (if applicable) a continuous stream of “H” characters in font 9. A pattern of continuous stream-scrolling black “H” on a white background was written to display. Played through the internal audio while the EMC testing was being done. The measurements were made while the system was exercised in this manner.





## Section 2: Test Facility and Procedure

### 2.1 Test Facility Used for Emission Testing

**Conducted Emissions Facilities:** Conducted Emissions were performed at Compliance Laboratory of Tech - Front (Shanghai) Computer Co, Ltd of No.68 Sanzhuang Road, Songjiang Export Processing Zone, Shanghai, P. R. China  
FCC Registration No. 602285  
VCCI Registration No. C-2529/ T-1836

**Radiated Emissions Facilities:** Radiated Emissions measurements were performed at Compliance Laboratory of Tech-Front (Shanghai) Computer Co., Ltd. of No.68 Sanzhuang Road, Songjiang Export Processing Zone, Shanghai, P. R. China

FCC Registration No. 602285

VCCI Registration No. R-2319 (10m Chamber)/ G-191 (10m Chamber) / R-3341 (3m-2Chamber) / G-209 (3m-2 Chamber) /R-2320 (3m Chamber site 1)

Note: "R-"to represent bellows 1GHz, "G-"to represent above 1GHz.

#### 2.1.1 Measurement Uncertainty

The measurement uncertainty has been determined to be the following:

AC Conducted Emissions = 3.2 dB

Telecom Conducted Emissions = 3.5 dB

Radiated Emissions (30MHz~1000MHz) = 4.1 dB

Radiated Emissions (1000MHz~18000MHz) = 4.6 dB

The equipment conforms to the requirement of CISPR 16-1, CISPR 16-4-2, ANSI C63.2 and other required standards.

Calibration of all test and measurement, including any accessories that may effect such calibration, is checked frequently to ensure the accuracy. Adjustments are made and correction factors are applied in accordance with the instructions contained in the respective manual.



### 2.1.2 Lab Accreditations

Coverage	Agency	Scope of Accreditation
USA	FCC	3/10 meter chamber and conducted test chamber to perform FCC Part 15/18 measurements
Japan	VCCI	3/10 meter chamber and conducted test chamber to perform radiated / conducted measurements
ISO/IEC 17025	CNAS	FCC 47CFR Part 15; CISPR22; AS/NZS CISPR 22; V-3/2008.04; GB9254; GB17625.1; EN55022; EN61000-3-2; EN 61000-3-3; CISPR24; EN55024; IEC/EN61000-4-2; IEC/EN61000-4-3; IEC/EN61000-4-4; IEC/EN61000-4-5; IEC/EN61000-4-6; IEC/EN61000-4-8; IEC/EN61000-4-11

### 2.1.3 Software to Exercise EUT

The EUT was tested using special test software called H patterns, which exercises all external I/O ports as well as the internal storage media by writing and reading (if applicable) a continuous stream of "H" characters in font 9. A pattern of continuous stream-scrolling black "H" on a white background was written to display. Played through the internal audio while the EMC testing was being done. The measurements were made while the system was exercised in this manner.

### 2.1.4 Special Accessories

There were no special accessories used during these tests.

### 2.1.5 Equipment Modifications and Deviations

There is no EUT modification or test standard deviation.



### 2.1.6 Test Configuration

The EUT was configured as a worst case system configuration as a result from pre-testing as described below:

#### Arrangement Block Diagram

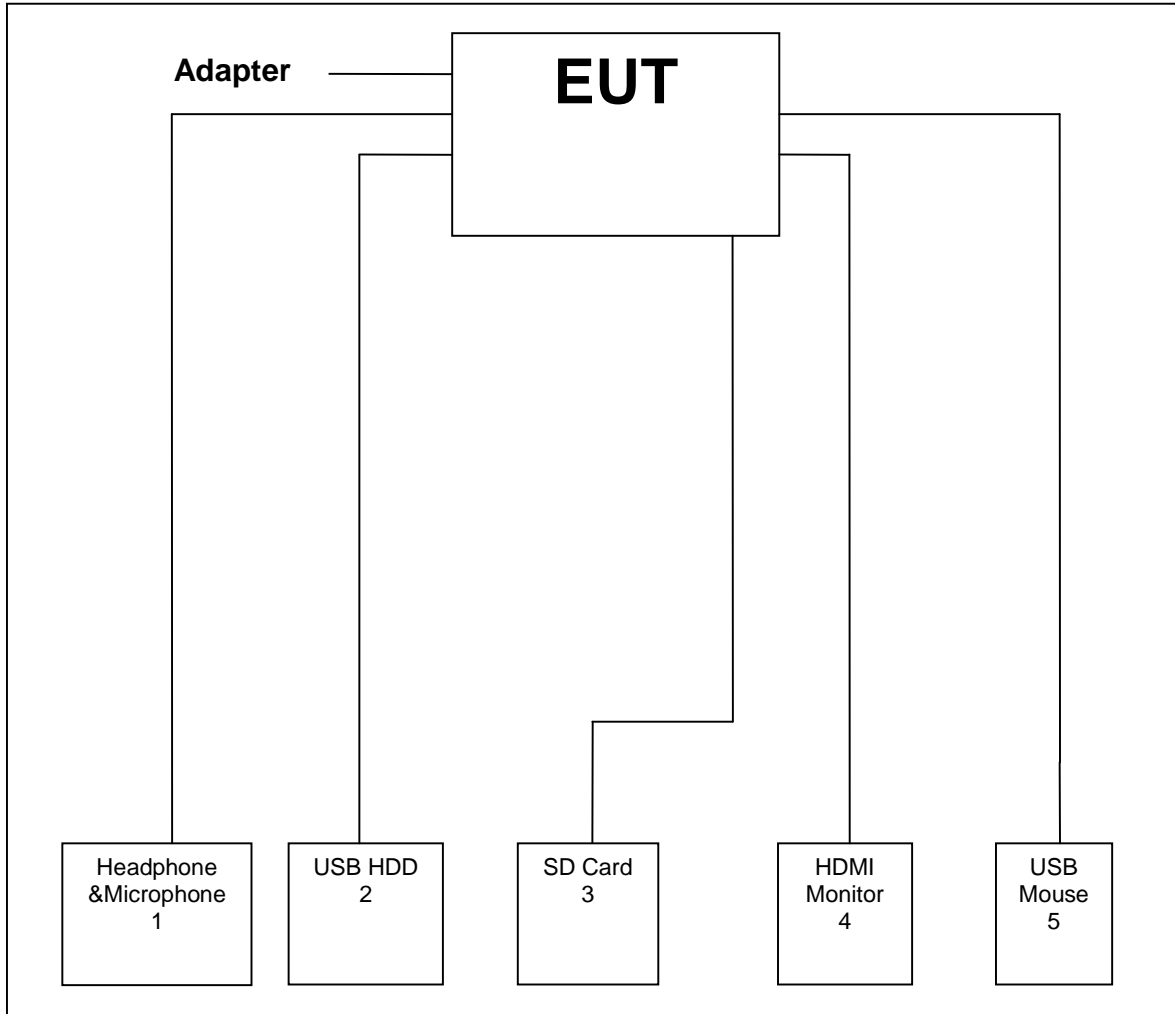

#### Associated Equipments

No.	Interference	Equipment	Brand	Model
1	Audio in & out port	Mic & Headphone	Philips	SHM3300
2	USB port	HDD	Seagate	5VCA0X2F
3	SD Card port	SD Card	Kingston	4GB
4	HDMI port	Monitor	DELL	2709Wb
5	USB port	Mouse	Logitech	M-BP82



**Pre-test configuration**

Prior to taking the formal emissions data collected in this report many hours of pre-testing have been performed. The selection of the worst case system documented in this report was based upon this pre-testing.

Mode	CPU	LCD Panel	Memory	EMMC	WLAN	Camera	Battery	Adapter
1	Marvell PXA2128 (1.0GHz)	CHIMEI G075ADE-T01	1GB	4GB	QMI EM113-MV	SUYIN CM031B-SE01	BYD CL1	Bestec NA0241WAA
2	Marvell PXA2128 (1.2GHz)	CHIMEI G075ADE-T01	2GB	8GB	Liteon WCBN603MH	SUYIN CM0316-OLPC01	BYD CL1	Bastec BT-AG250SDF
3	Marvell PXA2128 (1.0GHz)	CHIMEI G075ADE-T01	2GB	4GB	QMI EM113-MV	FOXLINK FE03FF-317H	STL XO-1	Darfon BU24-1203
4	Marvell PXA2128 (1.2GHz)	CHIMEI G075ADE-T01	1GB	4GB	Liteon WCBN603MH	SUYIN CM0316-OLPC01	STL XO-1	Darfon BB0J-C
5	Marvell PXA2128 (1.0GHz)	CHIMEI G075ADE-T01	2GB	8GB	QMI EM113-MV	SUYIN CM031B-SE01	BYD CL1	Bastec BT-AG250SDF
6	Marvell PXA2128 (1.0GHz)	CHIMEI G075ADE-T01	1GB	8GB	Liteon WCBN603MH	FOXLINK FE03FF-317H	BYD CL1	Darfon BU24-1203
7	Marvell PXA2128 (1.0GHz)	CHIMEI G075ADE-T01	1GB	4GB	QMI EM113-MV	SUYIN CM031B-SE01	STL XO-1	Darfon BP24-1203
8	Marvell PXA2128 (1.2GHz)	CHIMEI G075ADE-T01	1GB	8GB	Liteon WCBN603MH	FOXLINK FE03FF-317H	BYD CL1	Bastec NA0241WAA
9	Marvell PXA2128 (1.0GHz)	CHIMEI G075ADE-T01	1GB	4GB	QMI EM113-MV	SUYIN CM0316-OLPC01	STL XO-1	Bastec NA0241WAA
10	Marvell PXA2128 (1.2GHz)	CHIMEI G075ADE-T01	2GB	4GB	Liteon WCBN603MH	SUYIN CM031B-SE01	BYD CL1	Darfon BP24-1203



**Worst Case for Final Testing (Mode 2 chosen)**

Component	Vendor	Part Number
CPU	Marvell	PXA2128 (1.2GHz)
LCD Panel	CHIMEI	G075ADE-T01
Memory	Hynix	2GB
EMMC	Toshiba	8GB
WLAN	Liteon	WCBN603MH
Camera	SUYIN	CM0316-OLPC01
Battery	BYD	CL1
Power Adapter	Bestec	BT-AG250SDF

**2.1.7 Cable Description and Information**

Cable Type	Shielded	Ferrite	Length
HDMI Monitor	Yes	No	1.50m
USB Mouse	No	No	1.80m
USB 2.0 HDD	Yes	No	1.50m
Audio In	No	No	1.80m
Audio Out	No	No	1.80m



## 2.2 Measurement Equipment

N/A is an abbreviation for Not Applicable. All equipments are traceable to CNAS calibration standards.

### 2.2.1 Conducted Emissions

Description	Manufacturer	Model No.	Serial No.	Calibrated Until
Test Receiver	Rohde & Schwarz	ESCI	100167	5/18/2013
LISN	Schwarz beck	NSLK8127	8127433	5/18/2013
LISN	Schwarz beck	NSLK8128	8128229	5/18/2013
TLISN	TeseQ	CDN ST08A	30189	5/18/2013
TLISN	TeseQ	ISN ST800	29453	5/18/2013
TLISN	FCC	FCC-TLISN-T4-02	20581	5/18/2013
TLISN	FCC	FCC-TLISN-T8-02	20445	5/18/2013
Probe	FCC	F-33-4	57	5/18/2013
Probe	FCC	F35	507	5/18/2013

### 2.2.2 Radiated Emissions

Description	Manufacturer	Model No.	Serial No.	Calibrated Until
Test Receiver	Rohde & Schwarz	ESCI	100166	5/18/2013
Test Receiver	Rohde & Schwarz	ESIB26	100307	5/18/2013
Spectrum Analyzer	Agilent	E7405A	MY42000093	5/18/2013
Bilog Antenna	Schwarz beck	VULB9168	9168-195	7/01/2013
Bilog Antenna	Schwarz beck	VULB9168	9168-198	7/01/2013
Horn Antenna	Schwarz beck	BBHA 9120D	409	5/03/2013
Preamplifier	Agilent	8447D	2944A10848	5/18/2013
Preamplifier	Agilent	8447D	2944A10847	5/18/2013
Preamplifier	Agilent	8449B	3008A02145	5/18/2013
Preamplifier	Agilent	8449B	3008A02146	5/18/2013
Software	ADT	ADT_Radiated_V7	N/A	N/A
Antenna Mast	Inn-co	MA4000	MA4000/101/9770 405/L	N/A
Antenna Mast	Inn-co	MA4000	MA4000/104/9770 405/L	N/A
Turn Table	Inn-co	DT3000-1T-C	DT3000-1T-C/22	N/A
Controller	Inn-co	CO2000	CO2000/218/9770 405/L	N/A

**2.2.3 Power Harmonics and Voltage Fluctuation/Flicker**

Description	Manufacturer	Model No.	Serial No.	Calibrated Until
AC Power Source	EMTest	ACS 500	V0523100459	5/18/2013
Harmonics & Flicker Analyzer	EMTest	DPA 500	V0523100458	5/18/2013
Software	EMTest	EMTest software	N/A	N/A

**2.2.4 Electrostatic Discharge (ESD) Immunity**

Description	Manufacturer	Model No.	Serial No.	Calibrated Until
ESD Simulator	Noiseken	ESS-2002	ESS0423758	5/23/2013
ESD Simulator	TESEQ	NSG435	6251	5/30/2013
ESD Simulator	Thermo	MINIZAP(TPC-2A)	0506331	5/30/2013

**2.2.5 Radiated Electromagnetic Field Immunity**

Description	Manufacturer	Model No.	Serial No.	Calibrated Until
Amplifier	Amplifier Research	150W1000	312368	5/18/2013
Amplifier	Amplifier Research	60S1G3 (M1)	312416	5/18/2013
Antenna	Amplifier Research	AT5080	312113	N/A
Antenna Tripod	Evergo	TP1000A	N/A	N/A
Field Monitoring	Amplifier Research	IF4000A	310906	N/A
Probe	Amplifier Research	FP6001	307201	5/18/2013
Power Meter	Boonton	4232A	142402	5/18/2013
Power Sensor	Boonton	51011EMC	33838	5/18/2013
Power Sensor	Boonton	51011EMC	33839	5/18/2013
Double-coupling	Amplifier Research	DC6180A	312192	N/A
Double-coupling	Amplifier Research	DC7144A	311989	N/A
Controller	Amplifier Research	SC1000M1	312477	N/A
Signal Generator	Rohde& Schwarz	SML03	102270	5/18/2013
Software	ADT	ADT_RS_V7	N/A	N/A

**2.2.6 Fast Transient/Burst Immunity**

Description	Manufacturer	Model No.	Serial No.	Calibrated Until
EFT Generator	EMTest	EFT500	V0523100450	5/18/2013
Clamp	EMTest	HFK	0605-08	5/18/2013
Software	EMTest	EMTest Software	N/A	N/A

**2.2.7 Surge Immunity**

Description	Manufacturer	Model No.	Serial No.	Calibrated Until
Telecom surge generator	EMTest	TSS 500 M10	0523100456	5/18/2013
Impulse Generator	EMTest	VCS 500 M10	V0523100451	5/18/2013
CDN	EMTest	CNV504 S4	V054221000813	N/A
CDN	EMTest	CNV504 S1	V0523100455	N/A
Software	EMTest	EMTest Software	N/A	N/A

**2.2.8 Conducted Disturbance/Induced Radio-Frequency Field Immunity**

Description	Manufacturer	Model No.	Serial No.	Calibrated Until
Continuous Wave Simulator	EMTest	CWS 500C	V053100457	5/18/2013
Attenuator	EMTest	ATT 6/75	1104-13	5/18/2013
CDN	EMTest	CDN-M2/M3	0705-02	5/18/2013
CDN	EMTest	CDN-T2	0705-01	5/18/2013
CDN	EMTest	CDN-T4	0705-01	5/18/2013
EM Clamp	EMTest	EM Clamp	35737	5/18/2013
CA M2/M3/AF3	EMTest	CA M2/M3/AF3	N/A	N/A
Coupling clamp	EMTest	HFK (-4)	0605-08	N/A
CDN	EMTest	CDN-M1	0705-01	N/A
CDN	EMTest	CDN-AF4	0705-01	N/A
Software	EMTest	EMTest Software	N/A	N/A





**2.2.9 Power Frequency Magnetic Field Immunity**

Description	Manufacturer	Model No.	Serial No.	Calibrated Until
Current transformer	EMTest	MC 2630 (-8)	0705-04	N/A
Motorized Variation	EMTest	MV 2616 (-8)	V0523100453	N/A
Power Fail Simulator	EMTest	UCS500M4-PFS	V0523100452	5/18/2013
Coil	EMTest	MS100	0605-1	5/18/2013
Software	EMTest	EMTest Software	N/A	N/A

**2.2.10 Voltage Dips and Short Interruptions**

Description	Manufacturer	Model No.	Serial No.	Calibrated Until
Power Fail Simulator	EMTest	UCS500M4-PFS	V0523100452	5/18/2013
Software	EMTest	EMTest Software	N/A	N/A



## **Section3: Electromagnetic Emissions Test**

### **3.1 Emission**

#### **3.1.1 Line Conducted Emissions Test**

##### **- Measurement Procedures Utilized for Conducted Emissions**

The EUT was set up as per the test configuration to simulate typical usage per the user's manual. When the EUT is a tabletop system, a wooden table with a height of 0.8 meters is used and is placed on the ground plane as per EN 55022.

Associated equipment, if needed, was placed as per EN 55022.

All I/O cables were positioned to simulate typical actual usage as per EN 55022.

The test equipment EUT installed received AC power through a Line Impedance Stabilization Network (LISN), which supplied power source and was grounded to the ground plane.

All associated equipment received power from a second LISN.

For conducted emission test on telecommunication ports, a telecommunication port is connected by its signal cable to an impedance stabilization network (ISN). During the testing, the LAN utilization is in excess of 10 % and sustains that level for a minimum of 250 ms. the traffic rate is monitored by the program of Net Speed.

The EUT test program was started. Emissions were measured on each current carrying line of the EUT using an EMI Test Receiver connected to the LISN powering the EUT.

The Receiver scanned from 150 KHz to 30MHz for emissions in each of the test modes.

During the above scans under battery charging mode, the emissions were maximized by cable manipulation.

The EUT configuration and cable configuration of the above highest emission level were recorded for reference of the final test.



**- Limits**

**For AC Power**

Frequency (MHz)	Class A (dBuV)		Class B (dBuV)	
	Quasi-peak	Average	Quasi-peak	Average
0.15 - 0.5	79	66	66 - 56	56 - 46
0.50 - 5.0	73	60	56	46
5.0 - 30.0	73	60	60	50

- Note:** 1) The lower limit shall apply at the transition frequencies.  
 2) The limit decreases in line with the logarithm of the frequency in the range of 0.15MHz to 0.50MHz.  
 3) All emanations from a class A/B digital device or system, including any network of conductors and apparatus connected thereto, shall not exceed the level of field strengths specified above.

**For ISN**

**For Class A Equipment**

FREQUENCY (MHz)	Voltage Limit (dBuV)		Current Limit (dBuA)	
	Quasi-peak	Average	Quasi-peak	Average
0.15 ~ 0.5	97 ~ 87	84 ~ 74	53 ~ 43	40 ~ 30
0.5 ~ 30.0	87	74	43	30

- Note:** 1) The limits decrease linearly with the logarithm of the frequency in the range 0.15 MHz to 0.5MHz.  
 2) The current and voltage disturbance limits are derived for use with an impedance stabilization network (ISN) which presents a common mode (asymmetric mode) impedance of 150Ω to the telecommunication port under test (conversion factor is  $20\log_{10}150=44\text{dB}$ ).

**For Class B Equipment**

FREQUENCY (MHz)	Voltage Limit (dBuV)		Current Limit (dBuA)	
	Quasi-peak	Average	Quasi-peak	Average
0.15 - 0.5	84 ~ 74	74 ~ 64	40 ~ 30	30 ~ 20
0.5 – 30.0	74	64	30	20

- Note:** 1) The limits decrease linearly with the logarithm of the frequency in the range 0.15 MHz to 0.5MHz.  
 2) The current and voltage disturbance limits are derived for use with an impedance stabilization network (ISN) which presents a common mode (asymmetric mode) impedance of 150Ω to the telecommunication port under test (conversion factor is  $20\log_{10}150 = 44\text{dB}$ ).



- Test Setup

**For AC power setup as below**

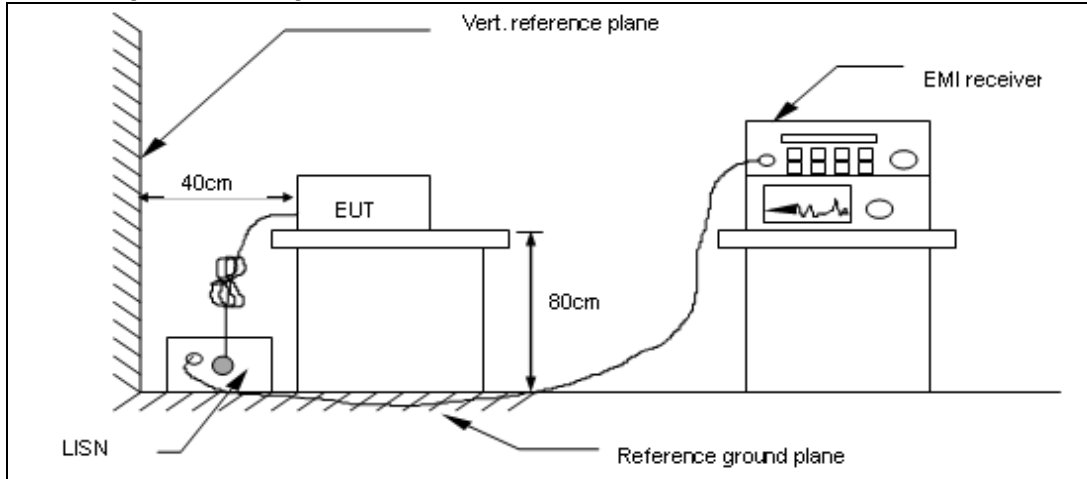

**For ISN setup as below**

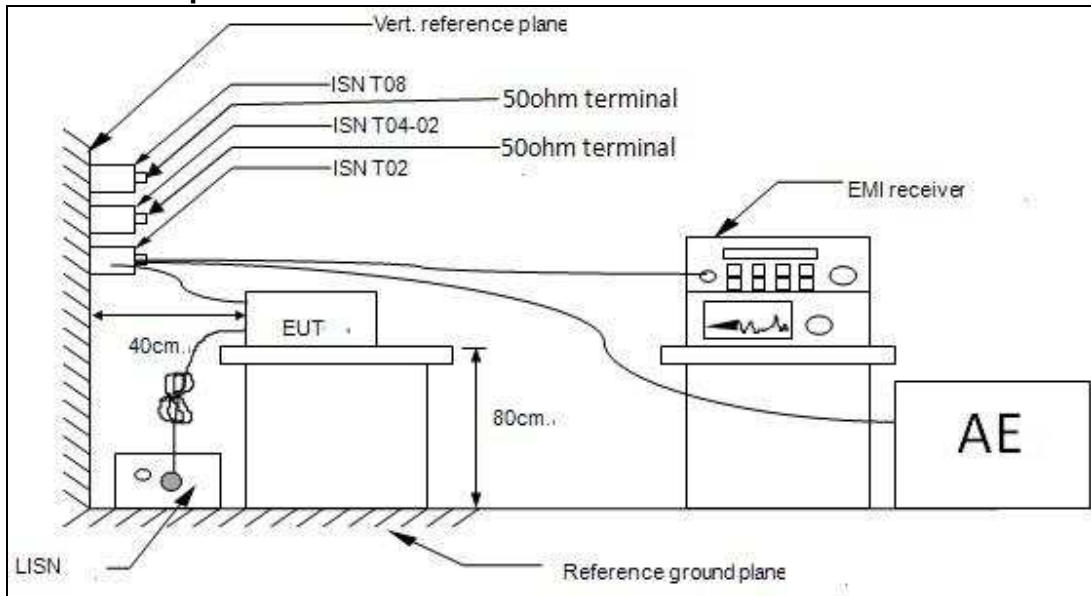

For the actual test configuration, please refer to the related item–Photographs of the Test Configuration.



**Conducted Emissions Test Data**

Engineer :Xingming zhao	Location : Conduction Room
Limit : EN55022 Class B	Probe : Line 1
EUT : Laptop Computer	Date : 2013-01-09
Power : AC 230V/50Hz	Detector: Quasi peak and Average
Temperature. : 22°C Relative Humidity.: 54% Atmospheric Pressure.: 101kpa	

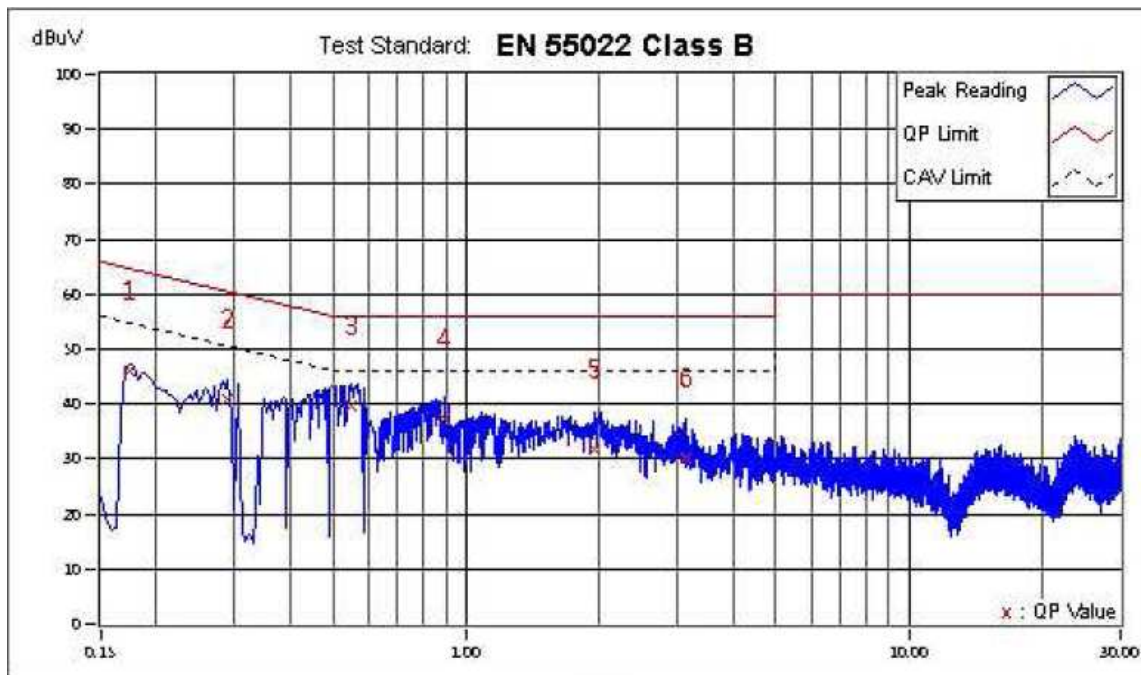

No.	Frequency MHz	Corr. Factor dB	Reading dBuV		Emission dBuV		Limit dBuV		Margins dB	
			QP	CAV	QP	CAV	QP	CAV	QP	CAV
1	0.17410	11.80	35.32	20.22	47.12	32.02	64.77	54.77	-17.65	-22.75
2	0.29009	10.99	30.23	17.61	41.22	28.60	60.52	50.52	-19.30	-21.92
+3	0.55007	10.59	28.99	9.40	39.58	19.99	56.00	46.00	-16.42	-26.01
4	0.89005	10.65	26.64	8.56	37.29	19.21	56.00	46.00	-18.71	-26.79
5	1.95397	10.55	21.13	3.79	31.68	14.34	56.00	46.00	-24.32	-31.66
6	3.12989	10.64	19.66	4.69	30.30	15.33	56.00	46.00	-25.70	-30.87

**Note:** 1) Conducted Emissions data was taken at 230Vac, 50Hz. This data was found to be equivalent or lower than the data listed above  
 2) Emission (dBuV) = Reading (dBuV) + Correction factor (dB)  
 Margins (dB) = Emission (dBuV) – Limit (dBuV)



Engineer : Xingming zhao	Location : Conduction Room
Limit : EN55022 Class B	Probe : Line 2
EUT : Laptop Computer	Date : 2013-01-09
Power : AC 230V/50Hz	Detector : Quasi peak and Average
Temperature. : 22°C Relative Humidity.: 54% Atmospheric Pressure.: 101kpa	

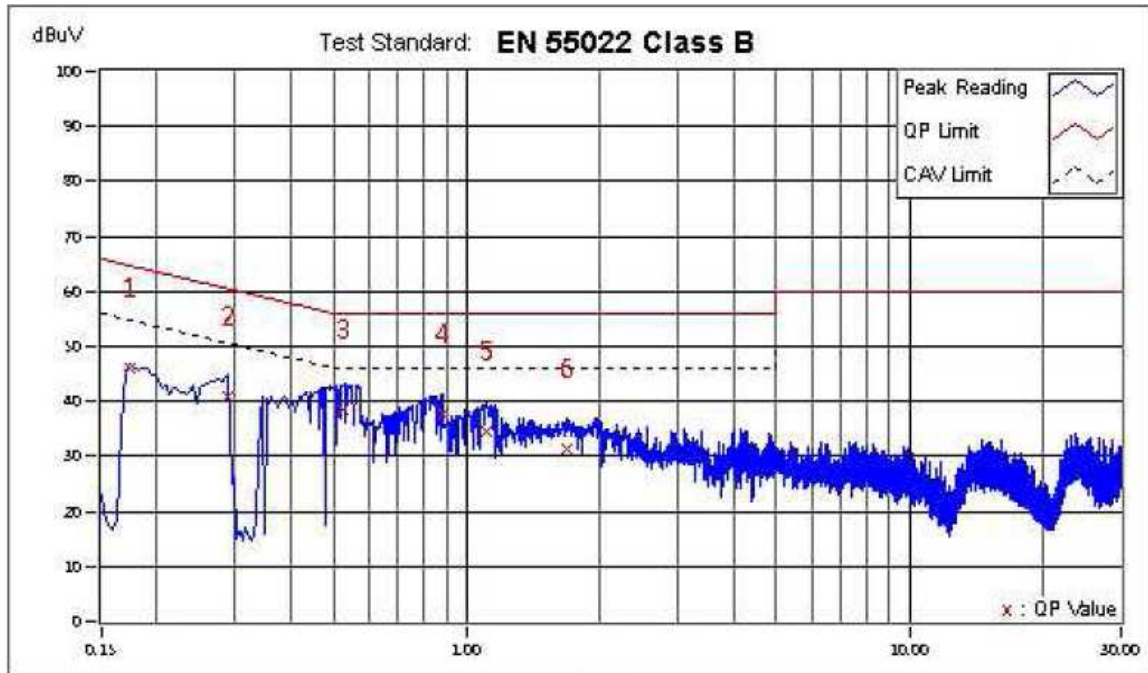

No.	Frequency MHz	Corr. Factor dB	Reading dBuV		Emission dBuV		Limit dBuV		Margins dB	
			QP	CAV	QP	CAV	QP	CAV	QP	CAV
1	0.17410	11.55	35.60	20.37	47.15	31.92	64.77	54.77	-17.62	-22.85
2	0.29009	10.79	30.40	16.92	41.19	27.71	60.52	50.52	-19.33	-22.81
+3	0.52607	10.53	28.05	9.20	38.58	19.73	56.00	46.00	-17.42	-26.27
4	0.88205	10.73	26.90	7.66	37.63	18.39	56.00	46.00	-18.37	-27.61
5	1.10603	10.71	23.77	4.23	34.48	14.94	56.00	46.00	-21.52	-31.06
6	1.67399	10.63	20.87	3.77	31.50	14.40	56.00	46.00	-24.50	-31.60

**Note:** 1) Conducted Emissions data was taken at 230Vac, 50Hz. This data was found to be equivalent or lower than the data listed above  
 2) Emission (dBuV) = Reading (dBuV) + Correction factor (dB)  
 Margins (dB) = Emission (dBuV) – Limit (dBuV)



### **3.1.2 Radiated Emissions Test**

#### **- Measurement Procedures Utilized for Radiated Emissions**

The equipment was set up as per the test configuration to simulate typical usage per the user's manual. When the EUT is a tabletop system, a wooden turntable with a height of 0.8 meters is used which is placed on the ground plane.

Associated equipment, if needed, was placed as per EN 55022.

All I/O cables were positioned to simulate typical usage as per EN 55022.

The EUT received AC power source, from the outlet socket under the turntable. All associated equipment received power from another socket under the turntable.

Mains cables, telephone lines or other connections to auxiliary equipment located outside the test are shall drape to the floor. No extension cords shall be used to mains receptacle.

The antenna was placed at 10 meter away from the EUT as stated in EN 55022. The antenna connected to the Receiver via a cable and at times a pre-amplifier would be used. The receiver scanned from 30MHz to 1000MHz. The EUT test program was started. Emissions were scanned under battery charging mode and measured rotating the EUT to 360 degrees and positioning the antenna 1 to 4 meters above the ground plane, in both vertical and horizontal polarization, to maximize the emission reading level.

The EUT was set 3 meters away from the interference-receiving antenna, which was mounted on the top of a variable-height antenna tower. The height of antenna can be varied from one meter to four meters; the height of adjustment depends on the EUT height and the antenna 3dB beam width both, to detect the maximum value of the field strength. Both horizontal and vertical polarizations of the antenna are set to make the measurement. For each suspected emission, the EUT was arranged to its worst case and then the antenna was tuned to heights and the rotatable table was turned from 0 degrees to 360 degrees to find the maximum reading. The test-receiver system was set to peak and average detect function and specified bandwidth with maximum hold mode when the test frequency is above 1 GHz

The test mode(s) described in Item 2.1.6 were scanned during the preliminary test:

After the preliminary scan, we found the test mode described in Item 2.1.6 producing the highest emission level.

The EUT and cable configuration, antenna position, polarization and turntable position of the above highest emission level were recorded for the final test.



**-Limits**

**For 30MHz~1000MHz**

FREQUENCY (MHz)	dBuV/m	
	Class A	Class B
30 ~ 230	40	30
230 ~ 1000	47	37

**NOTE:** 1) The lower limit shall apply at the transition frequencies.  
 2) Emission level (dBuV/m) = 20 log<sub>10</sub> Emission level (uV/m).

**For 1GHz~6GHz**

FREQUENCY (MHz)	dBuV/m	
	PK Limit	AV Limit
1GHz~3GHz	70	50
3GHz~6GHz	74	54

**NOTE:** 1) The lower limit shall apply at the transition frequencies.  
 2) Emission level (dBuV/m) = 20 log Emission level (uV/m).

**-Test Setup**

**For 30MHz~1000MHz test setup as below**

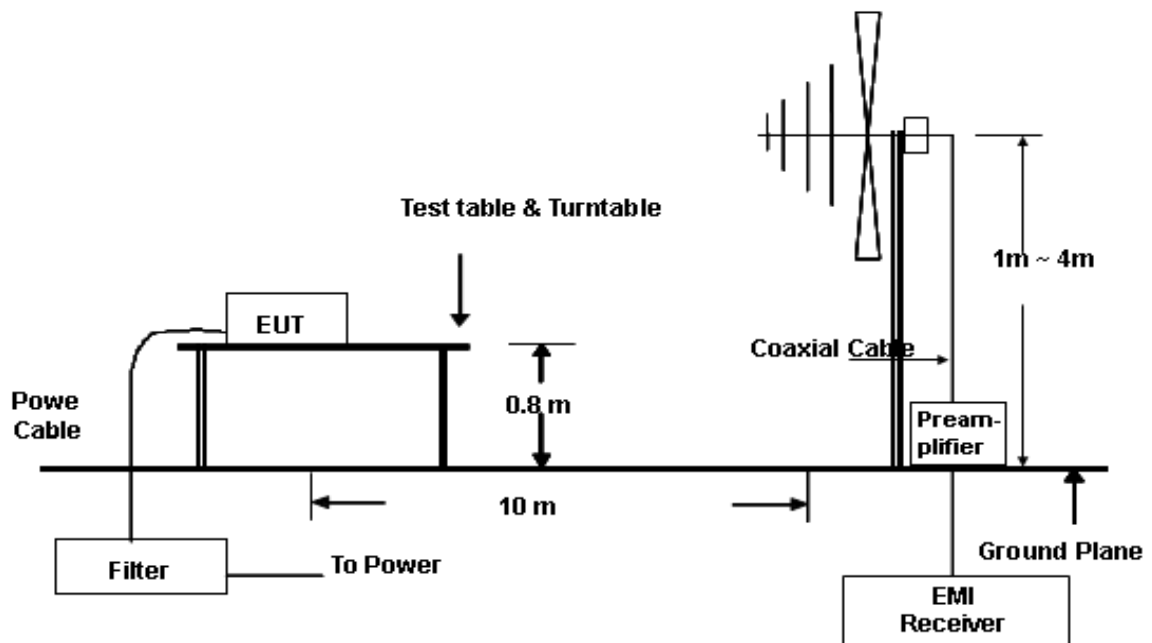





For 1GHz~6GHz test setup as below

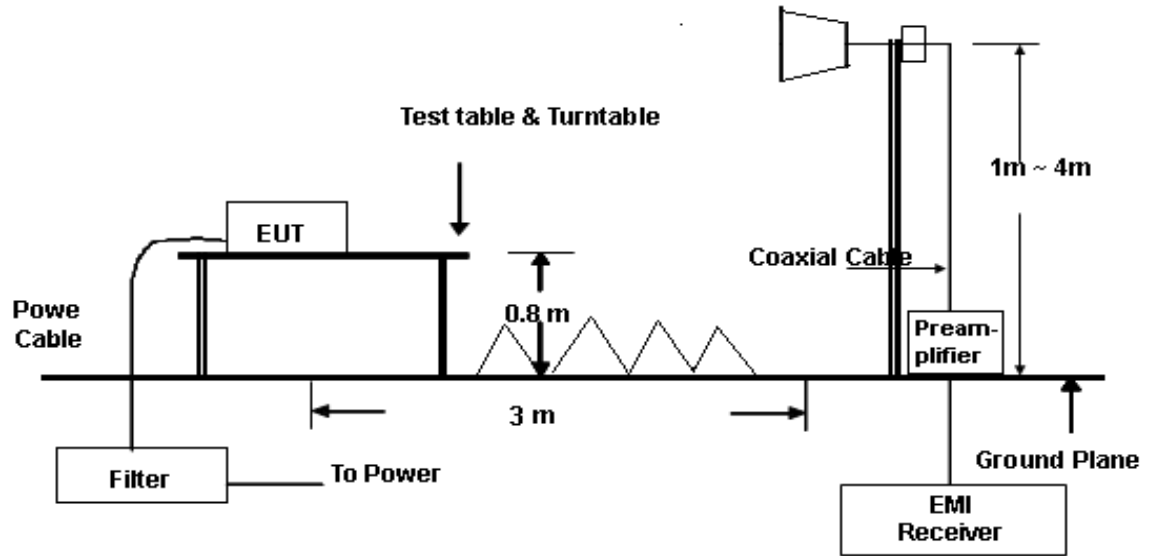

For the actual test configuration, please refer to the related item - Photographs of the Test Configuration.



**Radiated Emissions Test Data**

Engineer : Xingming zhao	Location : 10m Radiation Chamber
Limit : EN55022 Class B	Polarity : Vertical
EUT : Laptop Computer	Date : 2013-01-10
Power : AC 230V/50Hz	Detector : Quasi peak
Temperature. : 18°C Relative Humidity.: 56% Atmospheric Pressure.: 101kpa	

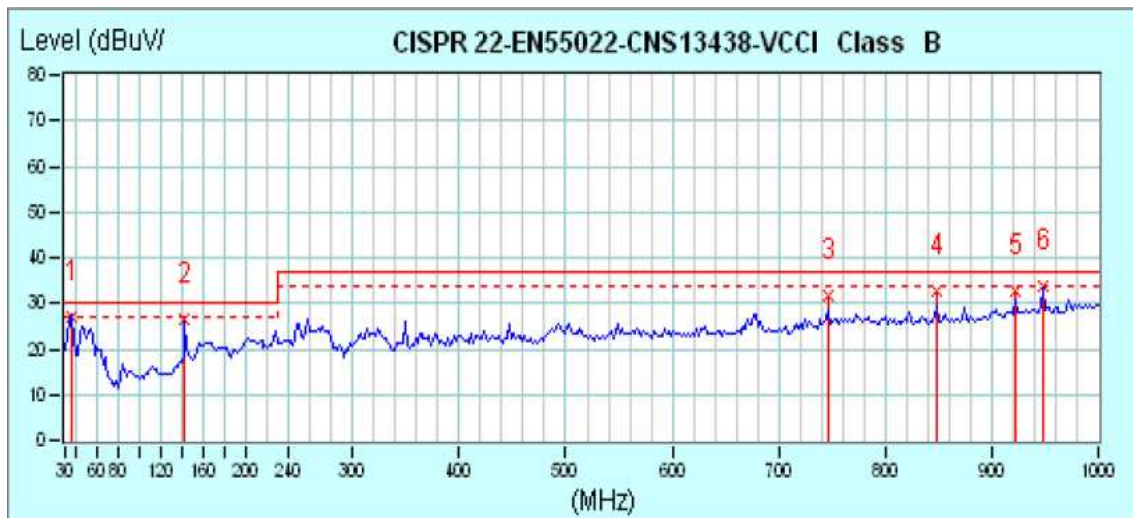

No.	Frequency MHz	Factor dB/m	Reading dBUV	Emission dBUV/m	Limit dBUV/m	Margin dB	Tower / Table cm	deg
*	1	13.50	13.45	26.95	30.00	-3.05	400	18
	2	14.67	11.71	26.38	30.00	-3.62	147	0
	3	25.98	5.90	31.88	37.00	-5.12	125	198
	4	27.07	5.67	32.74	37.00	-4.26	165	30
	5	28.46	4.18	32.64	37.00	-4.36	132	321
	6	28.55	5.20	33.75	37.00	-3.25	105	268

**Note:** 1).Radiated Emissions data was taken at 230Vac, 50Hz. This data was found to be equivalent or lower than the data listed above.

2).Emission (dBUV) = Reading (dBUV) + Correction factor (dB)

Margins (dB) = Emission (dBUV) – Limit (dBUV)



Engineer : Xingming zhao	Location : 10m Radiation Chamber
Limit : EN55022 Class B	Polarity : Horizontal
EUT : Laptop Computer	Date : 2013-01-10
Power : AC 230V/50Hz	Detector : Quasi peak
Temperature. : 18°C Relative Humidity.: 56% Atmospheric Pressure.: 101kpa	

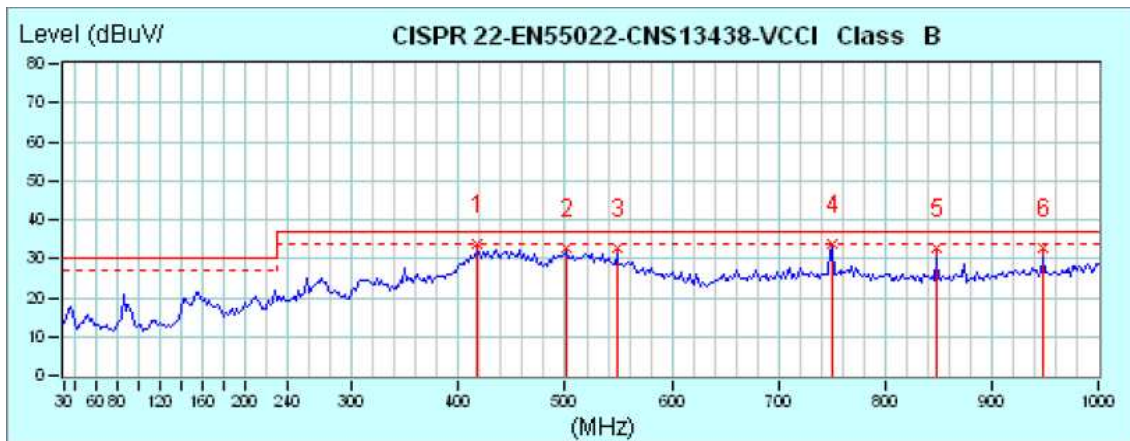

No.	Frequency MHz	Factor dB/m	Reading dBUV	Emission dBUV/m	Limit dBUV/m	Margin dB	Tower / Table cm	deg
1	417.99 (QP)	18.67	15.02	33.69	37.00	-3.31	158	293
2	501.42 (QP)	20.63	12.21	32.84	37.00	-4.16	105	298
3	547.98 (QP)	21.40	11.48	32.88	37.00	-4.12	155	301
*	749.76 (QP)	25.48	8.23	33.71	37.00	-3.29	152	196
5	848.74 (QP)	26.53	5.96	32.49	37.00	-4.51	159	296
6	947.66 (QP)	27.84	4.70	32.54	37.00	-4.46	247	131

**Note:** 1).Radiated Emissions data was taken at 230Vac, 50Hz. This data was found to be equivalent or lower than the data listed above.

2).Emission (dBUV) = Reading (dBUV) + Correction factor (dB)

Margins (dB) = Emission (dBUV) – Limit (dBUV)



Engineer : Xingming zhao	Location : 3m-2 Radiation Chamber
Limit : EN55022 Class B	Polarity : Vertical
EUT : Laptop Computer	Date : 2013-01-12
Power : AC 230V/50Hz	Detector : Peak & Average
Temperature. : 20°C Relative Humidity.: 60% Atmospheric Pressure.: 101kpa	

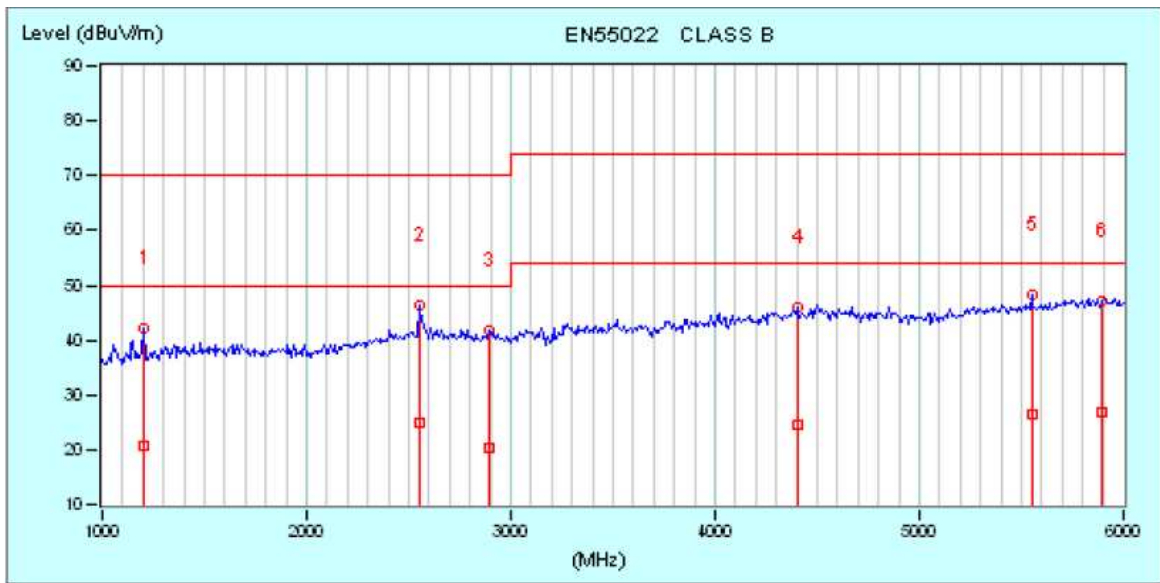

No.	Freq. MHz	C.F. dB/m	Reading		Emission		Limit		Margin		Ant./Table	
			PK	AV	PK	AV	PK	AV	PK	AV	cm	deg
1	1200.00	26.54	15.75	-5.87	42.29	20.67	70.00	50.00	-27.71	-29.33	132	354
* 2	2550.00	30.84	15.49	-6.01	46.33	24.83	70.00	50.00	-23.67	-25.17	134	159
3	2891.67	30.91	10.84	-10.44	41.75	20.47	70.00	50.00	-28.25	-29.53	153	347
4	4400.00	34.96	11.02	-10.38	45.98	24.58	74.00	54.00	-28.02	-29.42	145	162
5	5550.00	36.79	11.38	-10.43	48.17	26.36	74.00	54.00	-25.83	-27.64	162	147
6	5891.67	37.06	10.10	-10.35	47.16	26.71	74.00	54.00	-26.84	-27.29	133	314

**Note:** 1).Radiated Emissions data was taken at 230Vac, 50Hz. This data was found to be equivalent or lower than the data listed above.

2).Emission (dBUV) = Reading (dBUV) + Correction factor (dB)

Margins (dB) = Emission (dBUV) – Limit (dBUV)



Engineer : Xingming zhao	Location : 3m-2 Radiation Chamber
Limit : EN55022 Class B	Polarity : Horizontal
EUT : Laptop Computer	Date : 2013-01-12
Power : AC 230V/50Hz	Detector: Peak & Average
Temperature. : 20°C Relative Humidity.: 60% Atmospheric Pressure.: 101kpa	

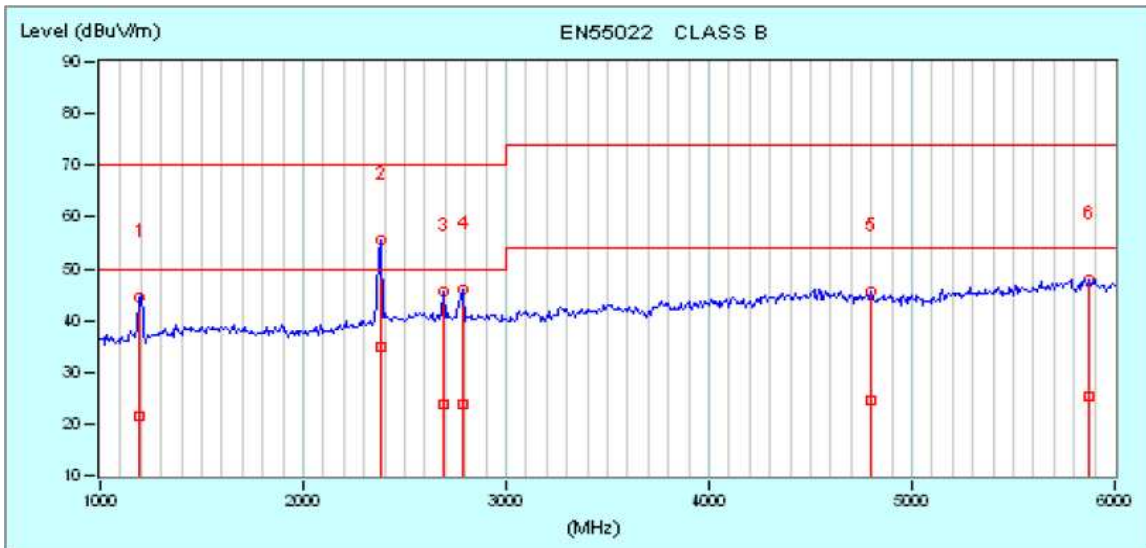

No.	Freq. MHz	C.F. dB/m	Reading		Emission		Limit		Margin		Ant./Table	
			PK	AV	PK	AV	PK	AV	PK	AV	cm	deg
1	1191.67	26.48	18.01	-4.83	44.49	21.85	70.00	50.00	-25.51	-28.35	103	346
2	2383.33	30.01	25.66	4.71	55.67	34.72	70.00	50.00	-14.33	-15.28	142	325
3	2691.67	30.76	14.97	-7.10	45.73	23.86	70.00	50.00	-24.27	-26.34	100	198
4	2783.33	30.82	15.21	-7.23	46.03	23.59	70.00	50.00	-23.97	-26.41	156	357
5	4800.00	34.58	11.03	-9.85	45.61	24.73	74.00	54.00	-28.39	-29.27	122	234
6	5875.00	37.04	10.93	-11.68	47.97	25.36	74.00	54.00	-26.03	-28.64	132	326

**Note:** 1). Radiated Emissions data was taken at 230Vac, 50Hz. This data was found to be equivalent or lower than the data listed above.  
 2). Emission (dBuV) = Reading (dBuV) + Correction factor (dB)  
 Margins (dB) = Emission (dBuV) – Limit (dBuV)



### 3.1.3 Power Harmonics Measurement

The product was tested and met the requirements specified in EN61000-3-2.

#### - Measurement Procedures Utilized for Harmonics

- 1) The EUT was placed on the top of a wooden table 0.8 meters above the ground and operated to produce the maximum harmonic components under normal operating conditions for each successive harmonic component in turn.
- 2) The classification of EUT is according to section 5 of EN 61000-3-2.
- 3) The EUT is classified as follows:
  - Class A: Balanced three-phase equipment, Household appliances excluding equipment as Class D, Tools excluding portable tools, Dimmers for incandescent lamps, audio equipment, equipment not specified in one of the three other classes.
  - Class B: Portable tools; Arc welding equipment which is not professional equipment.
  - Class C: Lighting equipment.
  - Class D: Equipment having a specified power less than or equal to 600 W of the following types: Personal computers and personal computer monitors and television receivers.
- 4) The correspondent test program of test instrument to measure the current harmonics emanated from EUT is chosen. The measure time shall be not less than the time necessary for the EUT to be exercised.



**- Test Setup**

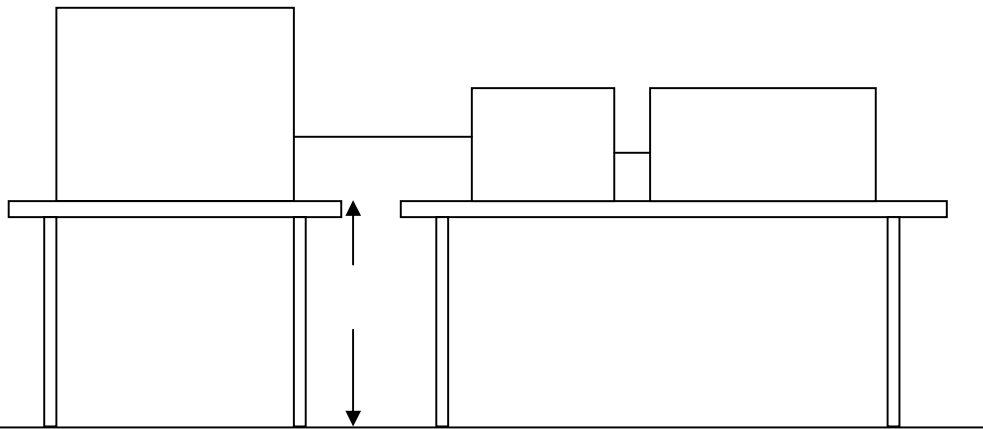

For the actual test configuration, please refer to the related item – Photographs of the Test Configuration.

**-Test Condition**

Equipment Tested	Laptop Computer
Test Software	H pattern
Test Standard	EN 61000-3-2
Test Operator	Xingming zhao
Date of Test	2013-01-13
Relative Humidity	58%
Temperature	20°C
Atmospheric Pressure	101kPa

**-Test Results**

<b>Fundamental voltage</b>	230V
<b>Power Frequency</b>	50Hz
<b>Observation Date</b>	150sec
<b>Power Consumption</b>	23.01W
<b>Power factor</b>	67.4%
<b>Test Result ( Pass/Fail)</b>	Pass

**Note:** According to EN61000-3-2 paragraph 7 the note1 and 2 are valid for all applications having an active input >75W, others the result should be pass.



### 3.1.4 Power Voltage Fluctuation/ Flicker Measurement

The product was tested and met the requirements specified in EN 61000-3-3

#### - Measurement Procedures Utilized for Flicker

- 1) The EUT was placed on the top of a wooden table 0.8 meters above the ground and operated to produce the most unfavorable sequence of voltage changes under normal operating conditions.
- 2) During the flick measurement, the measure time shall include that part of whole operation cycle in which the EUT produce the most unfavorable sequence of voltage changes. The observation period for short-term flicker indicator is 10 minutes.

#### - Test Setup

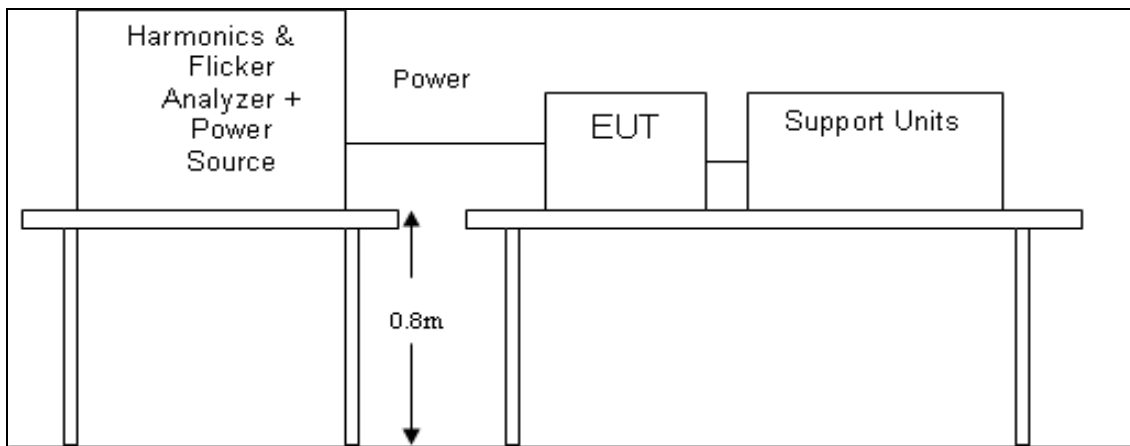

For the actual test configuration, please refer to the related item – Photographs of the Test Configuration.



**-Test Condition**

Equipment Tested	Laptop Computer
Test Software	H pattern
Test Standard	EN 61000-3-3
Test Operator	Xingming zhao
Date of Test	2013-01-13
Relative Humidity	58%
Temperature	20°C
Atmospheric Pressure	101kPa

**-Test Results**

	EUT Values	Limit	Result	Remark
$P_{st}$	0.028	1.00	Pass	$P_{st}$ means short-term flicker indicator
$P_{lt}$	0.028	0.65	Pass	$P_{lt}$ means long-term flicker indicator
$d_c$ [%]	0.005	3.30	Pass	$d_c$ means relative steady-state voltage change
$d_{max}$ [%]	0.077	4.00	Pass	$d_{max}$ means maximum relative voltage change
$d_t$ [s]	0.000	0.50	Pass	$T_{dt}$ means maximum Date that $d_t$ exceeds 3.3%



**3.2 Electromagnetic Immunity Report**  
**-General Description**

Product Standard	EN 55024:2010	
	Test Type	Minimum Requirement
Basic Standard	EN 61000-4-2	Electrostatic Discharge (ESD) 8kV for Air, 4kV for Contact Performance Criteria B
	EN 61000-4-3	Radio-frequency Electromagnetic field susceptibility (RS) 3V/m, 80%AM (1kHz), 80MHz-1000MHz, Performance Criteria A
	EN 61000-4-4	Electrical Fast transient/ Burst (EFT) Power Line:1kV, Signal:0.5kV Performance Criteria B
	EN 61000-4-5	Surge test 1.2/50us (open circuit voltage) 8/20us (short circuit current) AC Power port ( Line->ground 2kV, line->line 1kV) Communication Port (1.2/50us, 1kV) Performance Criteria B
	EN 61000-4-6	Conducted radio frequency disturbance test (CS) 150kHz-80MHz, 3Vrms, 80%AM (1kHz) Performance Criteria A
	EN 61000-4-8	Power Frequency Magnetic Field(PFMF) 50Hz ,1A/m Performance Criteria A
	EN 61000-4-11	<b>Voltage Dips:</b> 1) >95% reduction for 0.5 periods. Performance Criteria B 2) 30% reduction for 25 periods. Performance Criteria C <b>Voltage interrupt:</b> >95% reduction for 0.5 periods. Performance Criteria C



**-General performance criteria description**

<b>Criteria A</b>	The apparatus shell continues to operate as intended without operator intervention. No degradation of performance or loss of function is allowed below a performance level specified by the manufacturer, when the apparatus is used as intended. The performance level may be replaced by a permissible loss of performance. If the manufacturer does not specify the minimum performance level or the permissible performance loss, then either of these may be derived from the product description and documentation, and by what the user may reasonably expect from the equipment if used as intended.
<b>Criteria B</b>	After test, the apparatus shell continues to operate as intended without operator intervention. No degradation of performance or loss of function is allowed, after the application of the phenomenon below a performance level specified by the manufacturer, when the apparatus is used as intended. The performance level may be replaced by a permissible loss of performance. During the test, degradation of performance is however allowed. However, no change of operating state if stored data is allowed to persist after the test. If the manufacturer does not specify the minimum performance level or the permissible performance loss, then either of these may be derived from the product description and documentation, and by what the user may reasonably expect from the equipment if used as intended.
<b>Criteria C</b>	Temporary loss of function is allowed, provided the functions is self-recoverable or can be restored by the operation of controls by the user in accordance with the manufacturer instructions. Functions, and/or information stored in non-volatile memory, or protected by a battery backup, shall not be lost.



### 3.2.1 Electrostatic Discharge (ESD) Immunity Measurement

The product was tested and met the requirements specified in EN 61000-4-2

#### - Measurement Procedures Utilized for ESD

The discharges shall be applied in two ways:

a) Contact discharges to the conductive surfaces and coupling planes:

The EUT shall be exposed to at least 200 discharges, 100 each at negative and positive polarity, at a minimum of four test points. One of the test points shall be subjected to at least 50 indirect discharges to the center of the front edge of the Horizontal Coupling Plane (HCP). The remaining three test points shall each receive at least 50 direct contact discharges. If no direct contact test points, then at least 200 indirect discharges shall be applied in the indirect mode. Test shall be performed at a maximum repetition rate of one discharge per second.

b) Air discharges at slots and apertures and insulating surfaces:

On those parts of the EUT where it is not possible to perform contact discharge testing, the equipment should be investigated to identify user accessible points where breakdown may occur. Such points are tested using the air discharge method. This investigation should be restricted to those area normally handled by the user. A minimum of 10 single air discharges shall be applied to the selected test point for each such area.

The basic test procedure was in accordance with IEC 61000-4-2:

- a) The EUT was located 0.1 m minimum from all side of the HCP (dimensions 1.6m x 0.8m).
- b) The support units were located another table 30 cm away from the EUT, but direct support unit was/were located at same location as EUT on the HCP and keep at a distance of 10 cm with EUT.
- c) The time interval between two successive single discharges was at least 1 second.
- d) Contact discharges were applied to the non-insulating coating, with the pointed tip of the generator penetrating the coating and contacting the conducting substrate.
- e) Air discharges were applied with the round discharge tip of the discharge electrode approaching the EUT as fast as possible (without causing mechanical damage) to touch the EUT. After each discharge, the ESD generator was removed from the EUT and re-triggered for a new single discharge. The test was repeated until all discharges were complete.
- f) At least ten single discharges (in the most sensitive polarity) were applied at the front edge of each HCP opposite the center point of each unit of the EUT and 0.1 meters from the front of the EUT. The long axis of the discharge electrode was in the plane of the HCP and perpendicular to its front edge during the discharge.

- g) At least ten single discharges (in the most sensitive polarity) were applied to the center of one vertical edge of the Vertical Coupling Plane (VCP) in sufficiently different positions that the four faces of the EUT were completely illuminated. The VCP (dimensions 0.5m x 0.5m) was placed vertically to and 0.1 meters from the EUT.

**- Test Setup**

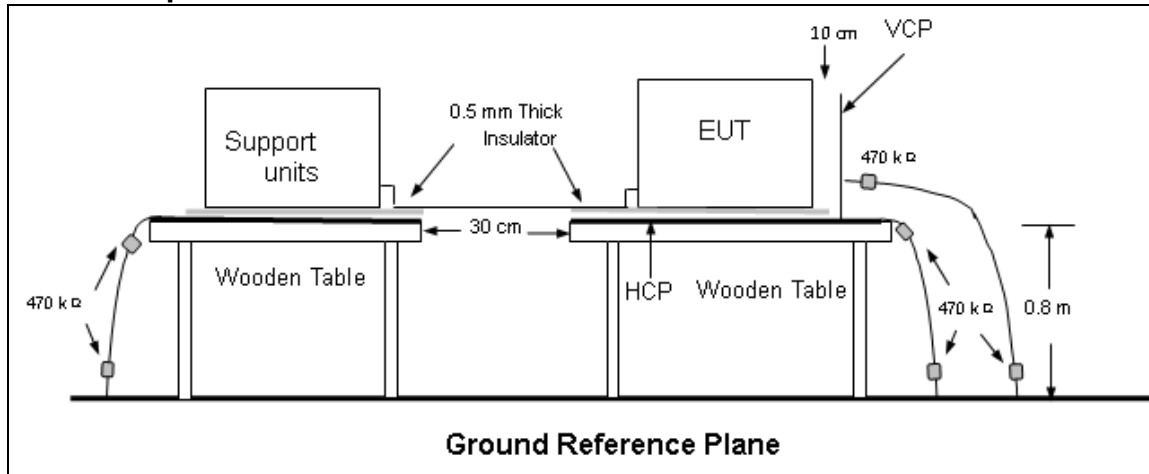

For the actual test configuration, please refer to the related item – Photographs of the Test Configuration.

**-Test Condition**

Equipment Tested	Laptop Computer
Test Software	H pattern
Test Standard	EN 61000-4-2
Test Operator	Xingming zhao
Date of Test	2013-01-12
Relative Humidity	50%
Temperature	26°C
Atmospheric Pressure	101kPa

**-Test Results**

<b>Amount of Discharge</b>	<b>Voltage</b>	<b>Coupling</b>	<b>Performance Criteria</b>	<b>Result (Pass/ Fail)</b>
10 /Point	± 2 kV	Air Discharge	B	Pass
10 /Point	± 4 kV	Air Discharge	B	Pass
10 /Point	± 8 kV	Air Discharge	B	Pass
25 /Point	± 2 kV	Contact Discharge	B	Pass
25 /Point	± 4 kV	Contact Discharge	B	Pass
25 /Point	± 2 kV	Indirect Discharge HCP	B	Pass
25 /Point	± 4 kV	Indirect Discharge HCP	B	Pass
25 /Point	± 2kV	Indirect Discharge VCP (Right)	B	Pass
25 /Point	± 4 kV	Indirect Discharge VCP (Right)	B	Pass
25 /Point	± 2 kV	Indirect Discharge VCP (Left)	B	Pass
25 /Point	± 4 kV	Indirect Discharge VCP (Left)	B	Pass

### 3.2.2 Radiated Electromagnetic Field Immunity Test

The product was tested and met the requirements specified in EN 61000-4-3

#### - Measurement Procedures Utilized for RS

- 1) The testing was performed in a fully anechoic chamber. The transmit antenna was located at a distance of 3 meters from the EUT.
- 2) The frequency range is swept from 80 MHz to 1000 MHz, with the signal 80% amplitude modulated with a 1 KHz sine-wave. The rate of sweep did not exceed  $1.5 \times 10^{-3}$  decade/s, where the frequency range is swept incrementally; the step size was 1% of preceding frequency value.
- 3) The dwell time at each frequency shall be not less than the time necessary for the EUT to be able to respond.
- 4) The test was performed with the EUT exposed to both vertically and horizontally polarized fields on each of the four sides.

#### - Test Setup

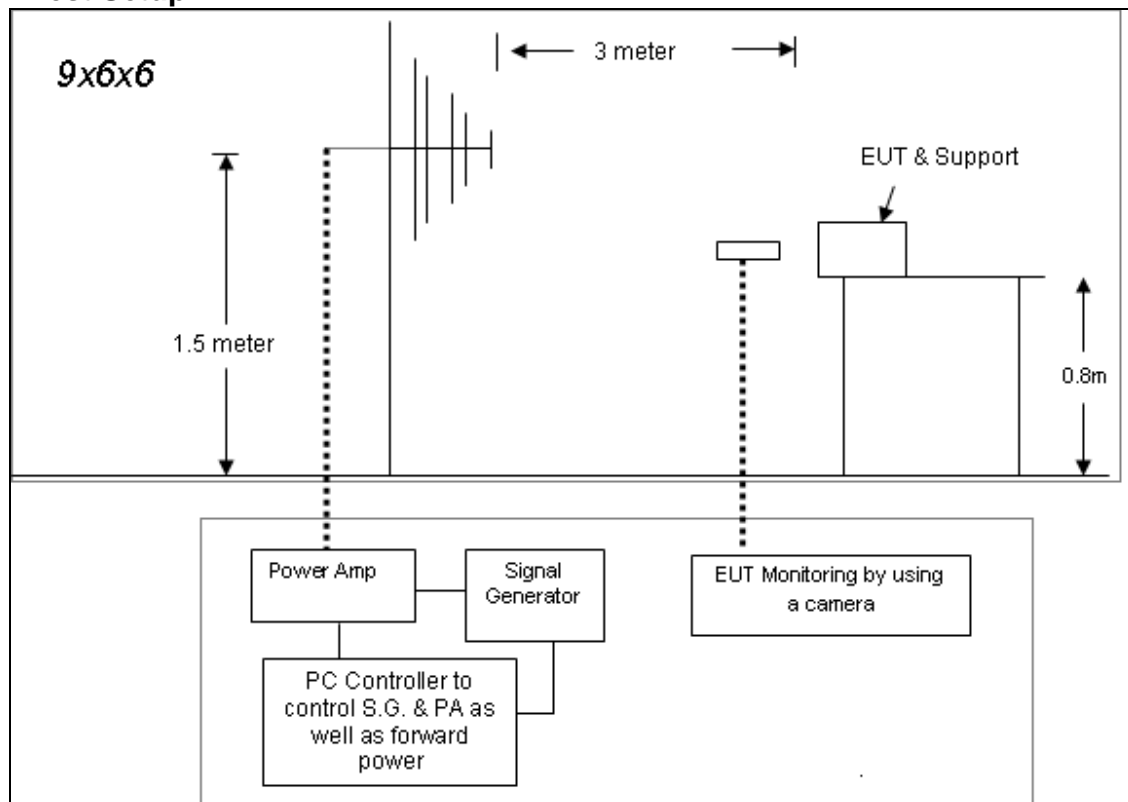

For the actual test configuration, please refer to the related item – Photographs of the Test Configuration.



**-Test Condition**

<b>Equipment Tested</b>	<b>Laptop Computer</b>
Test Software	H pattern
Test Standard	EN 61000-4-3
Test Operator	Xingming zhao
Date of Test	2013-01-12
Relative Humidity	60%
Temperature	20°C
Atmospheric Pressure	101kPa

**-Test Results**

Test level: 3V/m

Steps: 1 % of fundamental

Dwell Time: 3 sec

<b>Range (MHz)</b>	<b>Modulation</b>	<b>Polarity</b>	<b>Position</b>	<b>Performance Criteria</b>	<b>Result (Pass/Fail)</b>
80-1000	Yes	H	B/F/L/R	A	Pass
80-1000	Yes	V	B/F/L/R	A	Pass





### 3.2.3 Fast Transient/Burst Immunity Test

The product was tested and met the requirements specified in EN 61000-4-4

#### - Measurement Procedures Utilized for EFT

- 1) Both positive and negative polarity discharges were applied.
- 2) The length of the “hot wire” from the coaxial output of the EFT generator to the terminals on the EUT should not exceed 1 meter.
- 3) The duration time of each test sequential was 1 minute.
- 4) The transient/burst waveform was in accordance with EN 61000-4-4, 5/50ns.
- 5) AC Power Cord uses 0.5m+/-0.05m long cable otherwise AC power cord is in accordance with manufacture.

#### - Test Setup

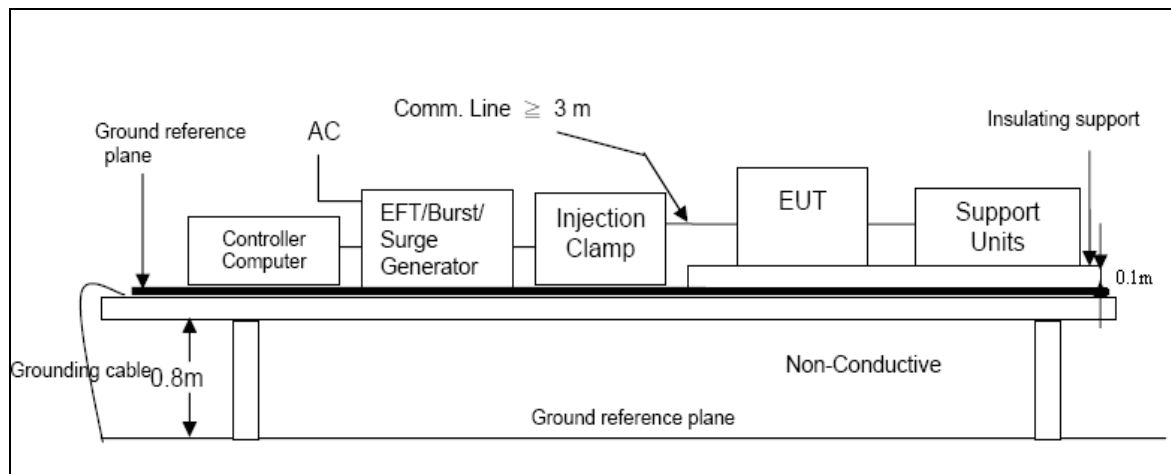
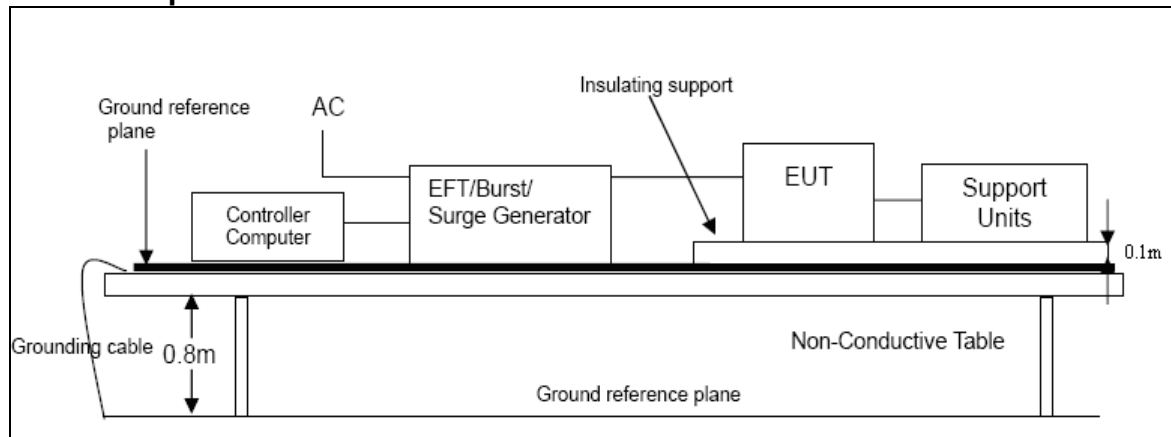

For the actual test configuration, please refer to the related item – Photographs of the Test Configuration



**-Test Condition**

<b>Equipment Tested</b>	<b>Laptop Computer</b>
Test Software	H pattern
Test Standard	EN 61000-4-4
Test Operator	Xingming zhao
Date of Test	2013-01-13
Relative Humidity	58%
Temperature	20°C
Atmospheric Pressure	101kPa

**-Test Results**

<b>Inject Line</b>	<b>Voltage</b>	<b>Inject Method</b>	<b>Performance Criteria</b>	<b>Result (Pass/ Fail)</b>
L	± 1 KV	Direct	B	Pass
N	± 1 KV	Direct	B	Pass
L + N	± 1 KV	Direct	B	Pass



### 3.2.4 Surge Immunity Test

The product was tested and met the requirements specified in EN 61000-4-5

#### - Measurement Procedures Utilized for Surge

1) For EUT power supply:

The surge is applied to the EUT power supply terminals via the capacitive coupling network. Decoupling networks are required in order to avoid possible adverse effects on equipment not under test that may be powered by the same lines, and to provide sufficient decoupling impedance to the surge wave. The power cord between the EUT and the coupling/decoupling networks was shorter than 2 meters in length.

2) For test applied to unshielded un-symmetrically operated interconnection lines of EUT:

The surge was applied to the lines via the capacitive coupling. The coupling / decoupling networks didn't influence the specified functional conditions of the EUT. The interconnection line between the EUT and the coupling/decoupling networks was shorter than 2 meters in length.

3) For test applied to unshielded symmetrically operated interconnection / telecommunication lines of EUT:

The surge was applied to the lines via gas arrestors coupling. Test levels below the ignition point of the coupling arrestor were not specified. The interconnection line between the EUT and the coupling/decoupling networks was shorter than 2 meters in length.

#### - Test Setup

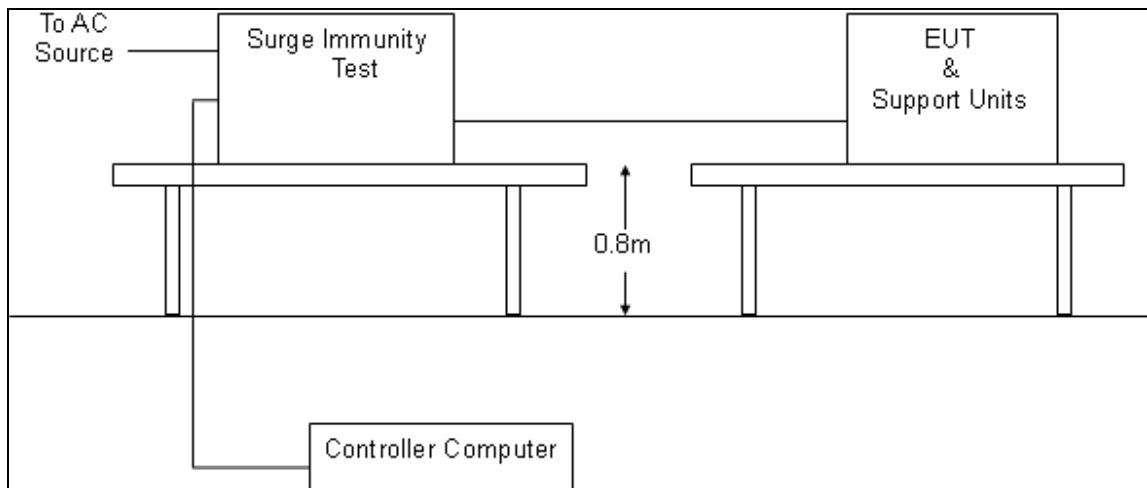

For the actual test configuration, please refer to the related item - Photographs of the Test Configuration.



**-Test Condition**

<b>Equipment Tested</b>	<b>Laptop Computer</b>
Test Software	H pattern
Test Standard	EN 61000-4-5
Test Operator	Xingming zhao
Date of Test	2013-01-13
Relative Humidity	58%
Temperature	20°C
Atmospheric Pressure	101kPa

**-Test Results**

<b>Coupling Line</b>	<b>Voltage</b>	<b>Polarity</b>	<b>Coupling Method</b>	<b>Performance Criteria</b>	<b>Result (Pass/Fail)</b>
L1-L2	1 KV	Positive	Capacitive	B	Pass
L1-L2	1 KV	Negative	Capacitive	B	Pass

### 3.2.5 Conducted Disturbance, Induced Radio-Frequency Field

The product was tested and met the requirements specified in EN 61000-4-6

#### - Measurement Procedures Utilized for CS

The EUT shall be tested within its intended operating and climatic conditions.

The test shall be performed with the test generator connected to each of the coupling and decoupling devices in turn, while the other non-excited RF input ports of the coupling devices are terminated by a 50-ohm load resistor.

The frequency range was swept from 150 kHz to 80MHz, using the signal level established during the setting process and with a disturbance signal of 80 % amplitude. The signal was modulated with a 1 kHz sine wave, pausing to adjust the RF signal level or the switch coupling devices as necessary. The sweep rate was  $1.5 \times 10^{-3}$  decades/s. Where the frequency range is swept incrementally, the step size was 1 % of preceding frequency value from 150 kHz to 80 MHz.

The dwell time at each frequency was less than the time necessary for the EUT to be exercised, and able to respond. Sensitive frequencies such as clock frequency (ies) and harmonics or frequencies of dominant interest, was analyzed separately.

Attempts were made to fully exercise the EUT during testing, and to fully interrogate all exercise modes selected for susceptibility.

#### - Test Setup

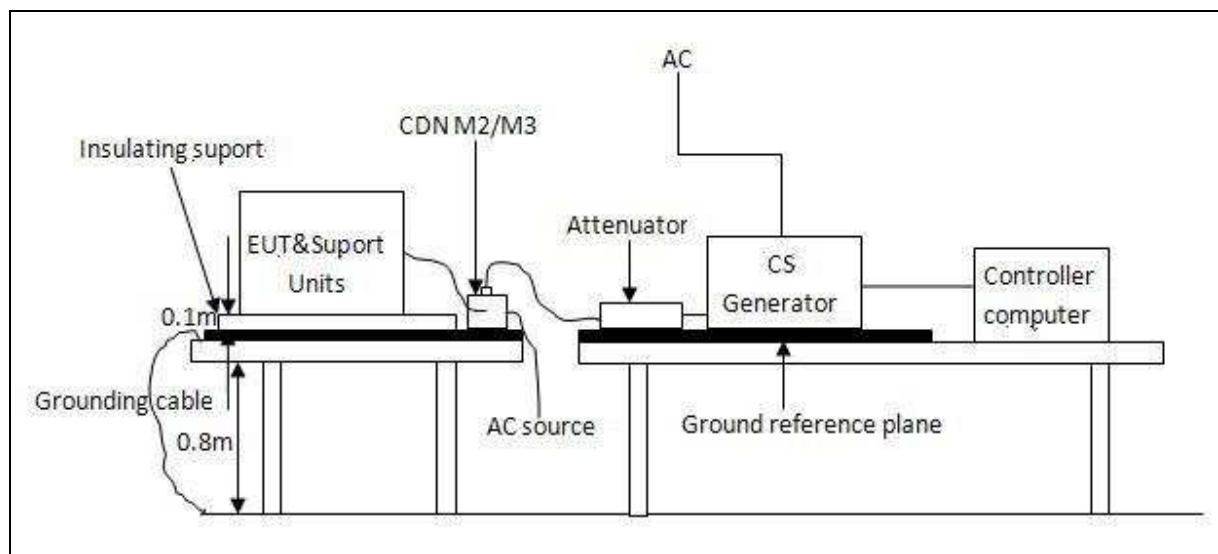

- Note:** 1). The EUT is setup 0.1m above Ground Reference Plane  
2). The CDNs and / or EM clamp used for real test depends on ports and cables configuration of EUT.  
For the actual test configuration, please refer to the related item –  
Photographs of the Test Configuration



**-Test Condition**

<b>Equipment Tested</b>	<b>Laptop Computer</b>
Test Software	H pattern
Test Standard	EN 61000-4-6
Test Operator	Xingming zhao
Date of Test	2013-01-13
Relative Humidity	58%
Temperature	20°C
Atmospheric Pressure	101kPa

**-Test Results**

Frequency Step: 1% of fundamental

Dwell Time: 3 sec

Test Ports: mains

<b>Range (MHz)</b>	<b>Field</b>	<b>Modulation</b>	<b>Performance Criteria</b>	<b>Result (Pass/ Fail)</b>
0.15-80	3V	Yes	A	Pass

### 3.2.6 Power Frequency Magnetic Field Immunity Test

The product was tested and met the requirements specified in EN 61000-4-8

#### - Measurement Procedures Utilized for PFMF

- 1) The equipment is configured and connected to satisfy its functional requirements. It shall be placed on the GRP with the interposition of a 0.1m-thick insulating support.
- 2) The equipment cabinets shall be connected to the safety earth directly on the GRP via the earth terminal of the EUT.
- 3) The power supply, input and output circuits shall be connected to the sources of power supply, control and signal.
- 4) The cables supplied or recommended by the equipment manufacturer shall be used. 1 meter of all cables used shall be exposed to the magnetic field.

#### - Test Setup

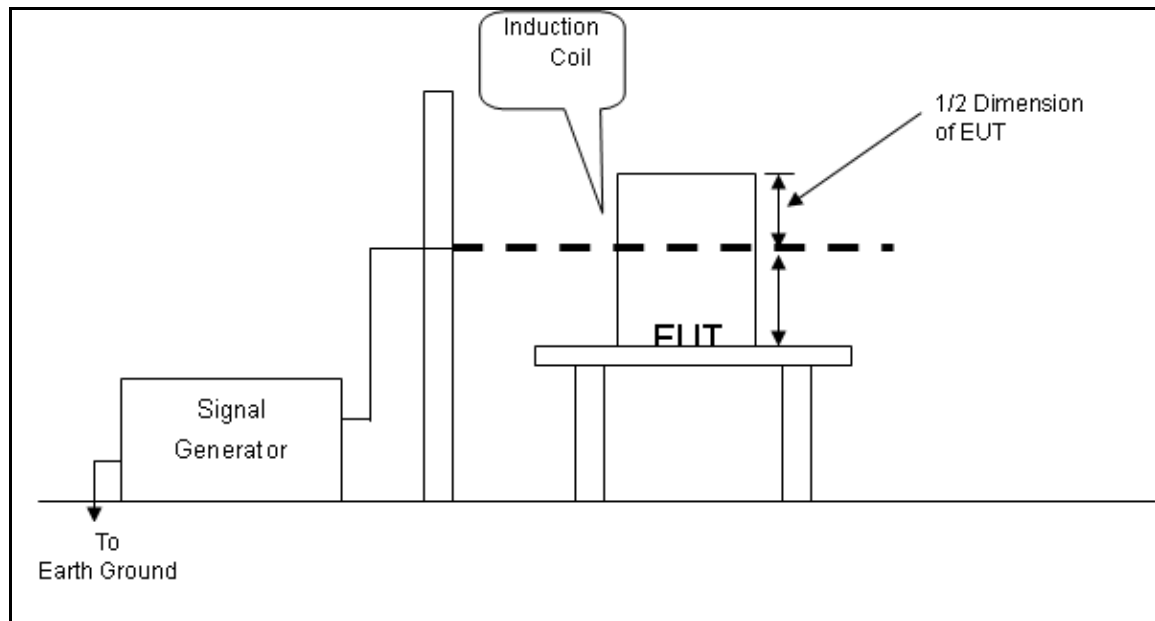

For the actual test configuration, please refer to the related item – Photographs of the Test Configuration.



**-Test Condition**

<b>Equipment Tested</b>	<b>Laptop Computer</b>
Test Software	H pattern
Test Standard	EN 61000-4-8
Test Operator	Xingming zhao
Date of Test	2013-01-13
Relative Humidity	58%
Temperature	20°C
Atmospheric Pressure	101kPa

**-Test Results**

Power Freq.: 50Hz

<b>Orientation</b>	<b>Field</b>	<b>Performance Criteria</b>	<b>Result (Pass/Fail)</b>
X	1A/m	A	Pass
Y	1A/m	A	Pass
Z	1A/m	A	Pass





### 3.2.7 Voltage Dips / Short Interruptions and Interruptions Test

The product was tested and met the requirements specified in EN 61000-4-11

#### - Measurement Procedures Utilized for Dips

- 1) The EUT and support units were located on a wooden table, 0.8 m away from ground floor.
- 2) Setting the parameter of tests and then perform the test software of test simulator.
- 3) Conditions changes to occur at 0 degree crossover point of the voltage waveform.
- 4) Recording the test result in test record form.

#### - Test Setup

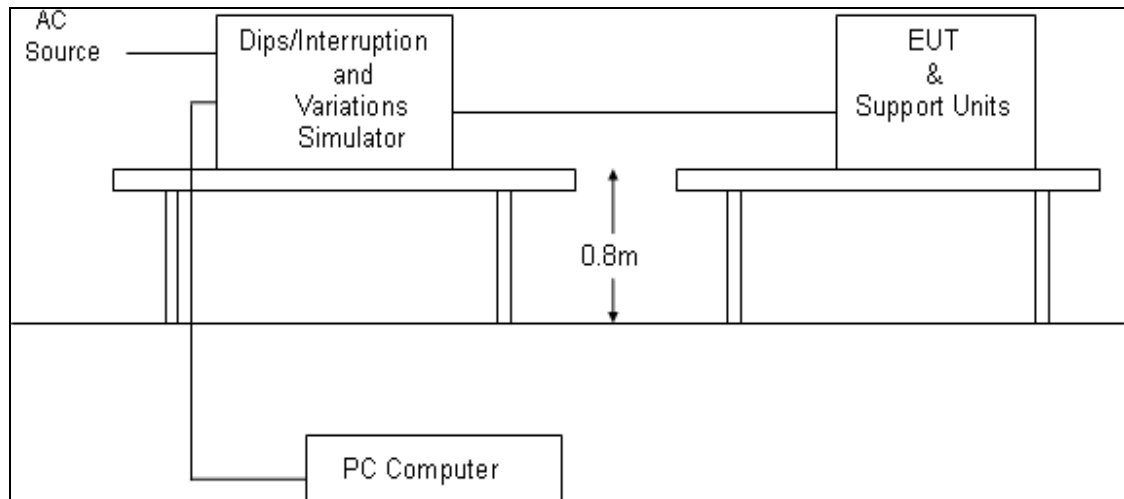

For the actual test configuration, please refer to the related item – Photographs of the Test Configuration.



**-Test Condition**

Equipment Tested	Laptop Computer
Test Software	H pattern
Test Standard	EN 61000-4-11
Test Operator	Xingming zhao
Date of Test	2013-01-13
Relative Humidity	58%
Temperature	20°C
Atmospheric Pressure	101k Pa

**-Test Results**

The duration with a sequence of three dips/interruptions with interval of 10s minimum (Between each test event)

**Voltage Dips:**

Test Level % U <sub>T</sub>	Reduction	Duration (periods)	Performance Criteria	Result (Pass/Fail)
0	> 95%	0.5	B	Pass
70	30%	25	C	Pass

**Voltage Interruptions:**

Test Level % U <sub>T</sub>	Reduction	Duration (periods)	Performance Criteria	Result (Pass/Fail)
0	> 95%	250	C	Pass



## SECTION 4: Test Arrangement Photos

### 4.1 Conducted Emissions (AC Power)

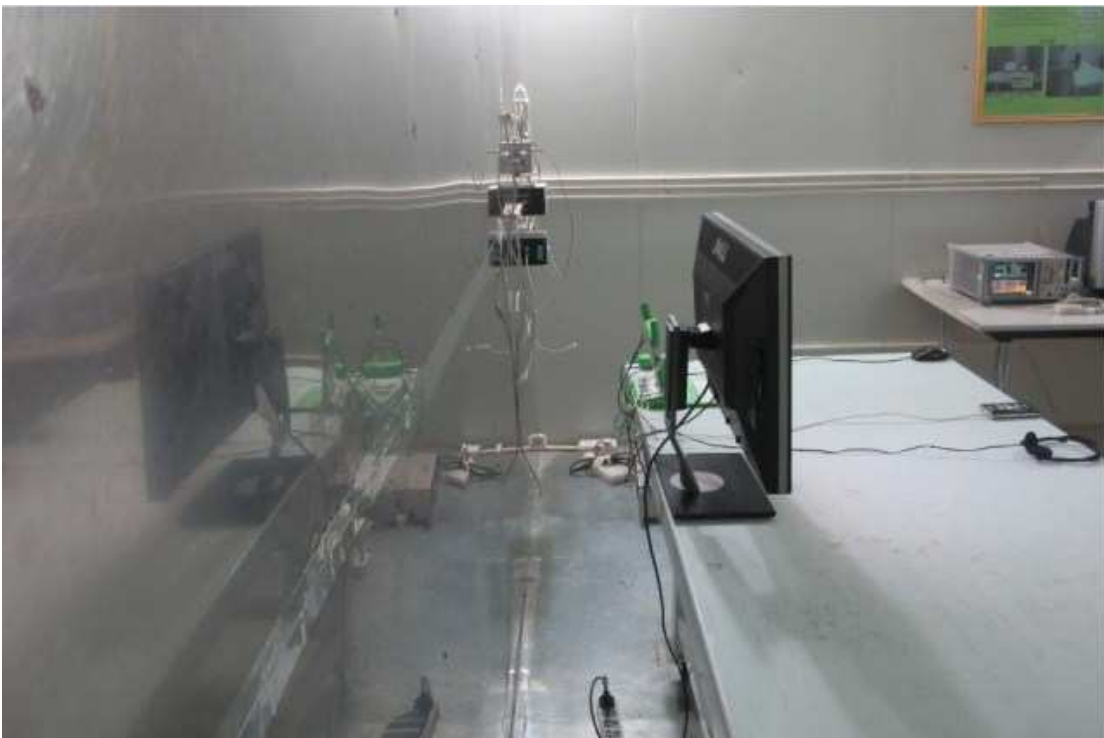



## 4.2 Radiated Emissions

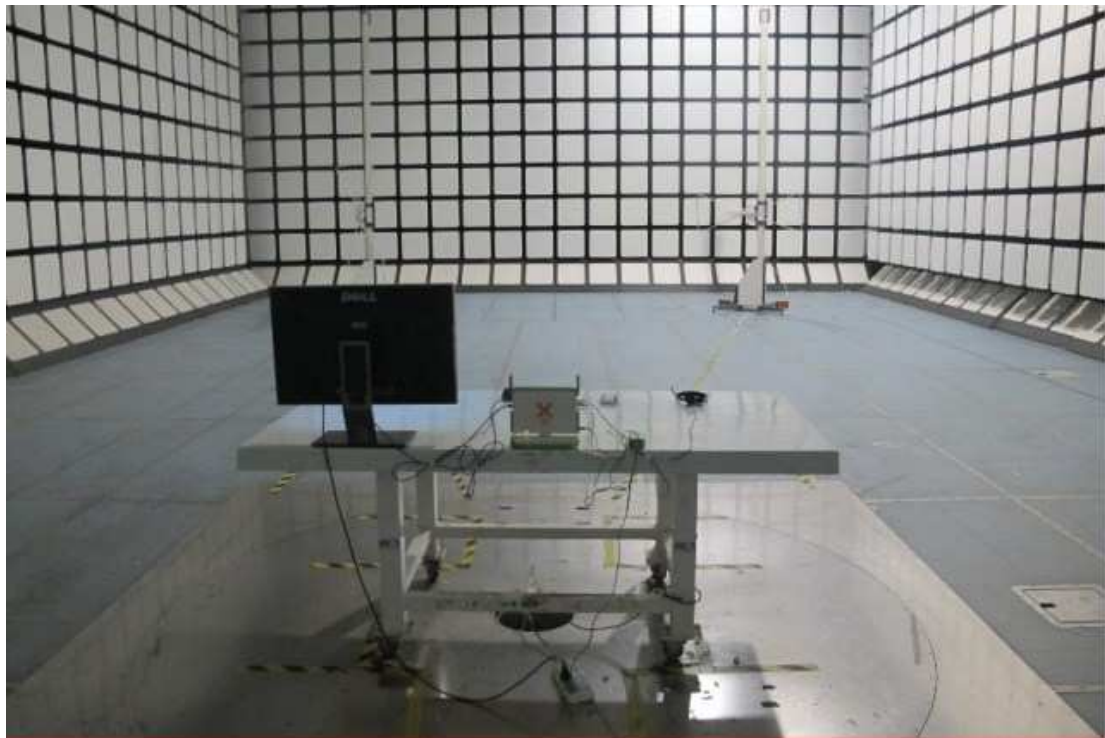





### 4.3 Power Harmonics and Flick Measurement

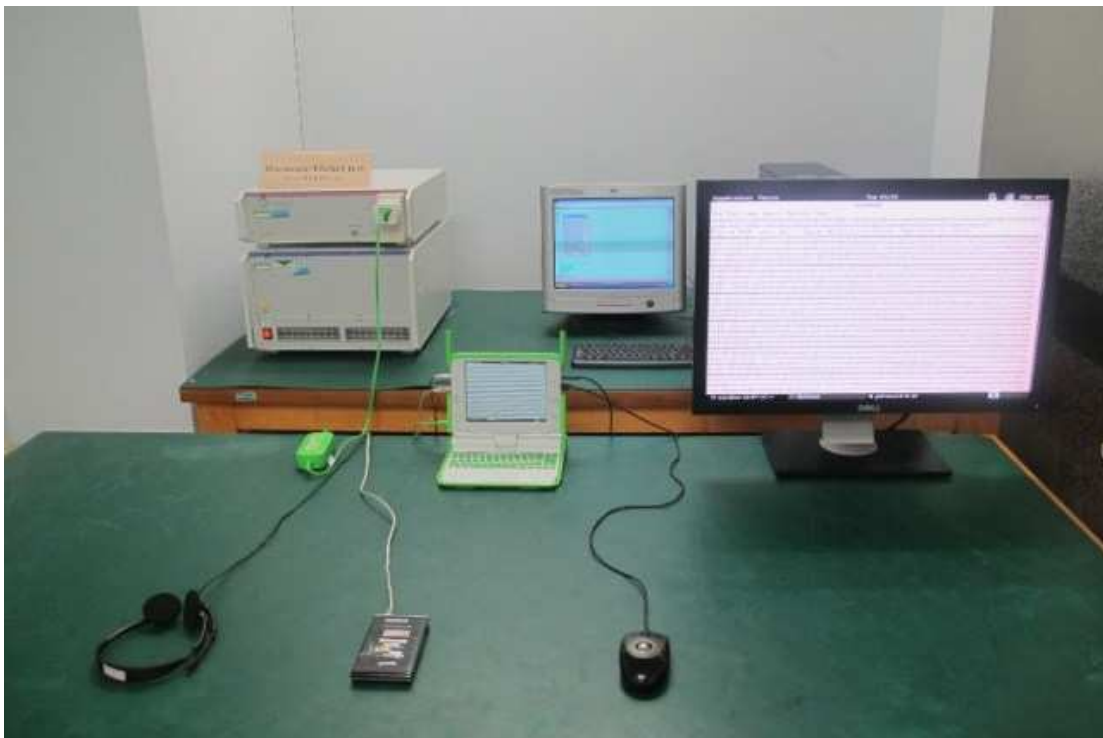
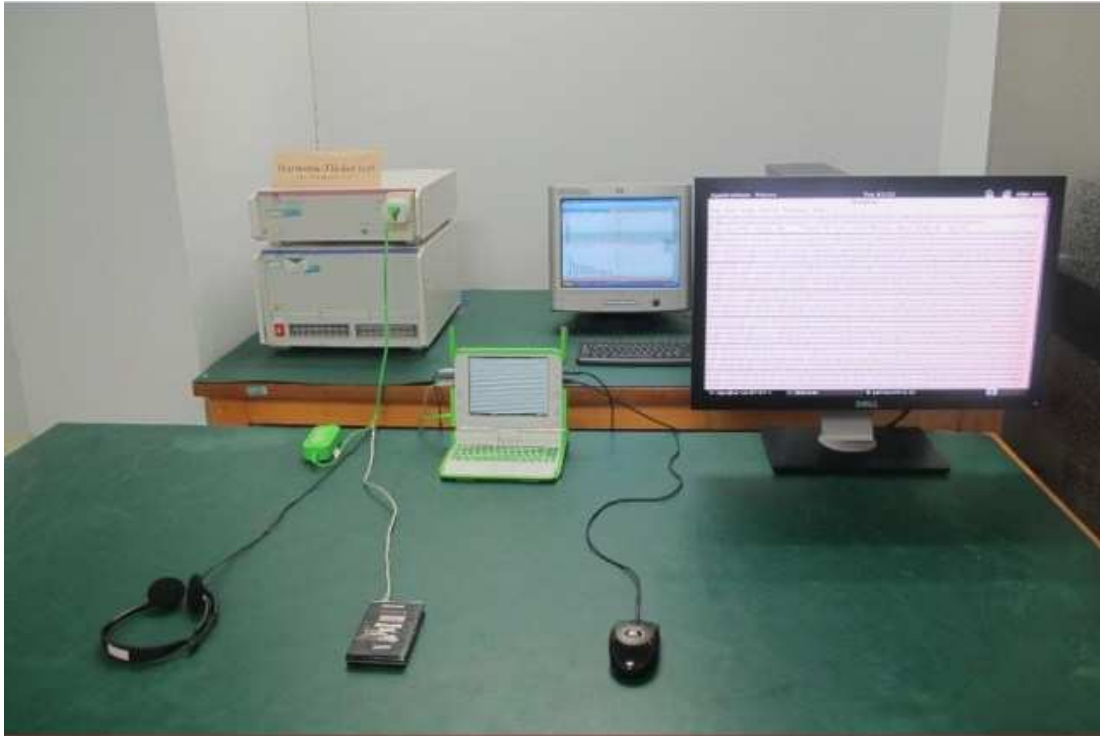



#### 4.4 Electrostatic Discharge (ESD)

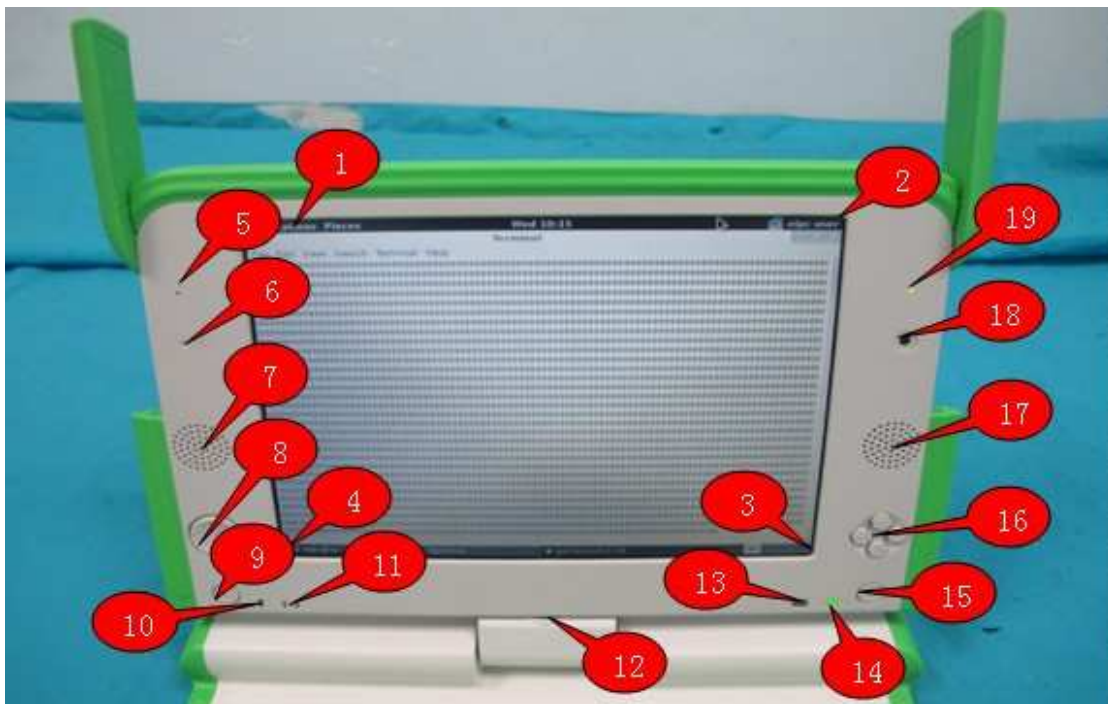

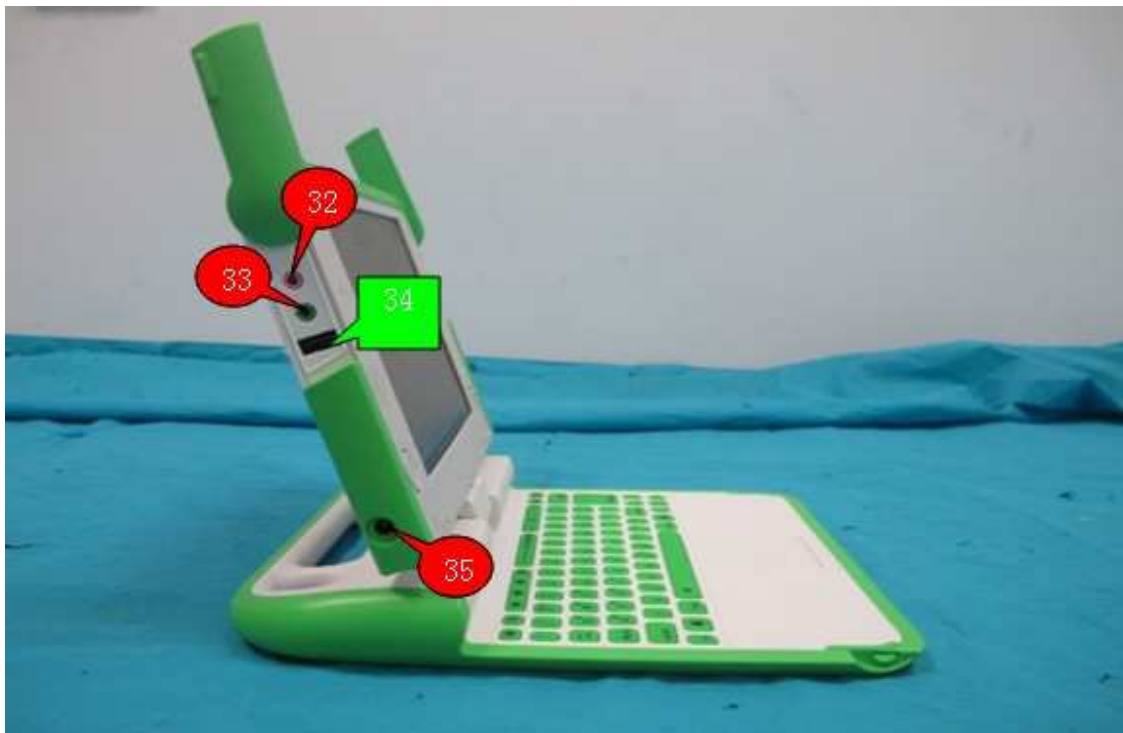
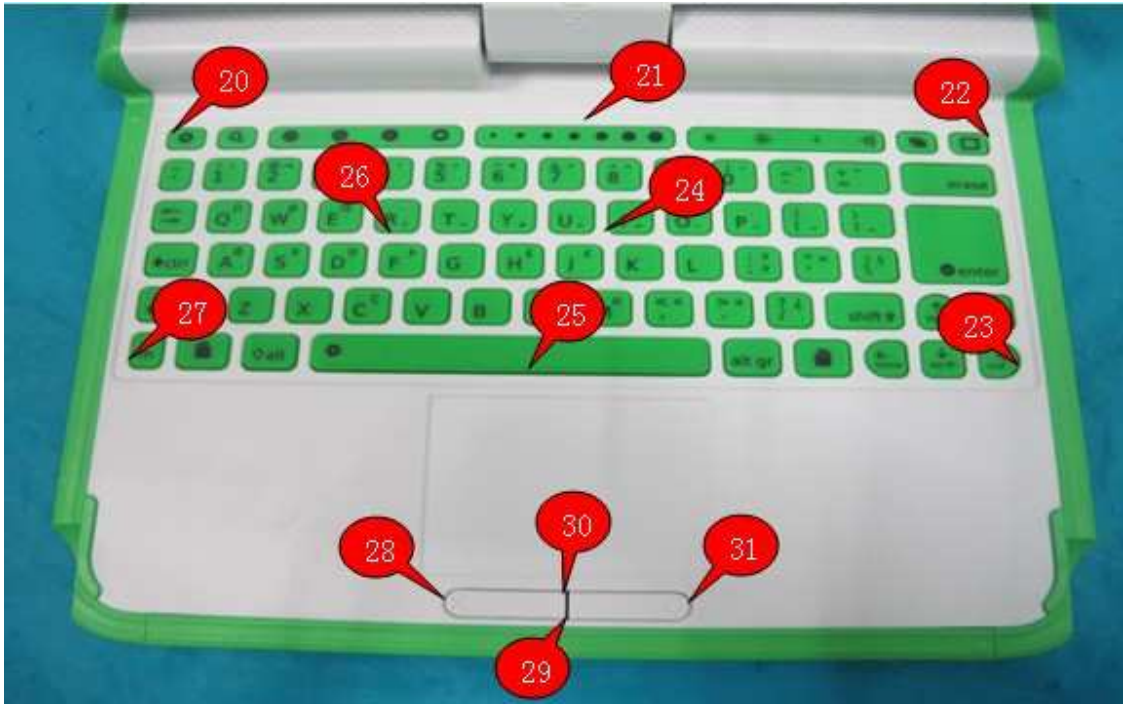



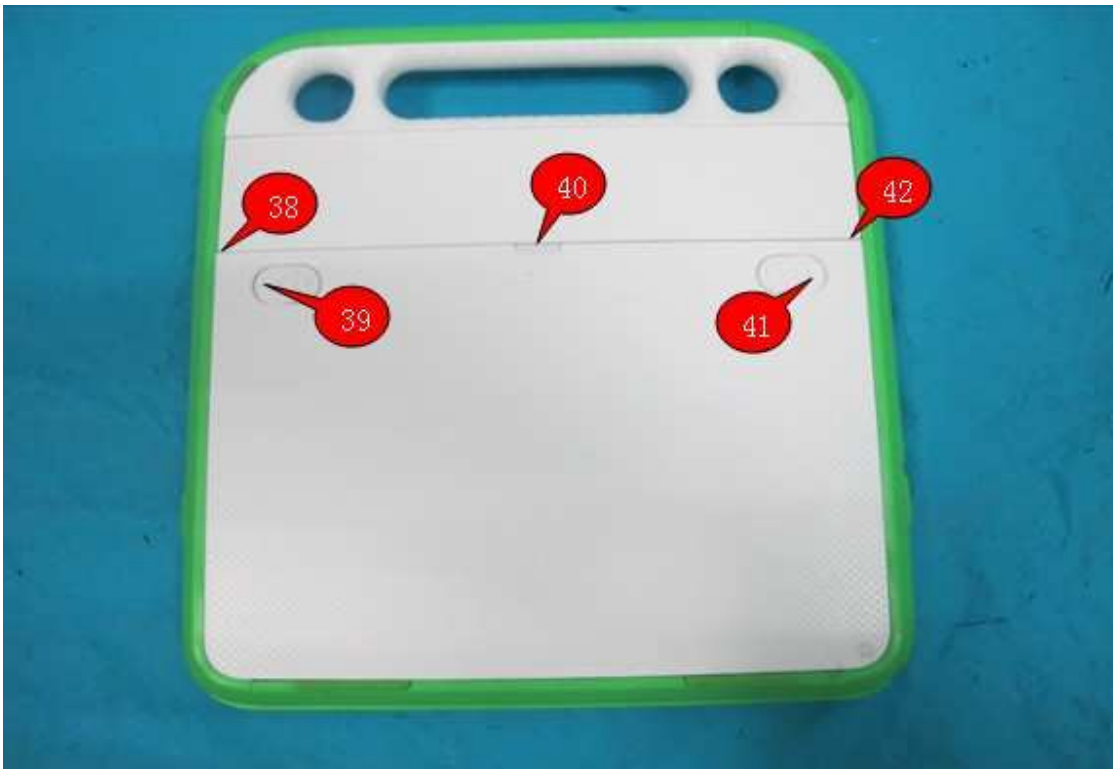



#### 4.5 Radiated Electromagnetic Field Immunity Test

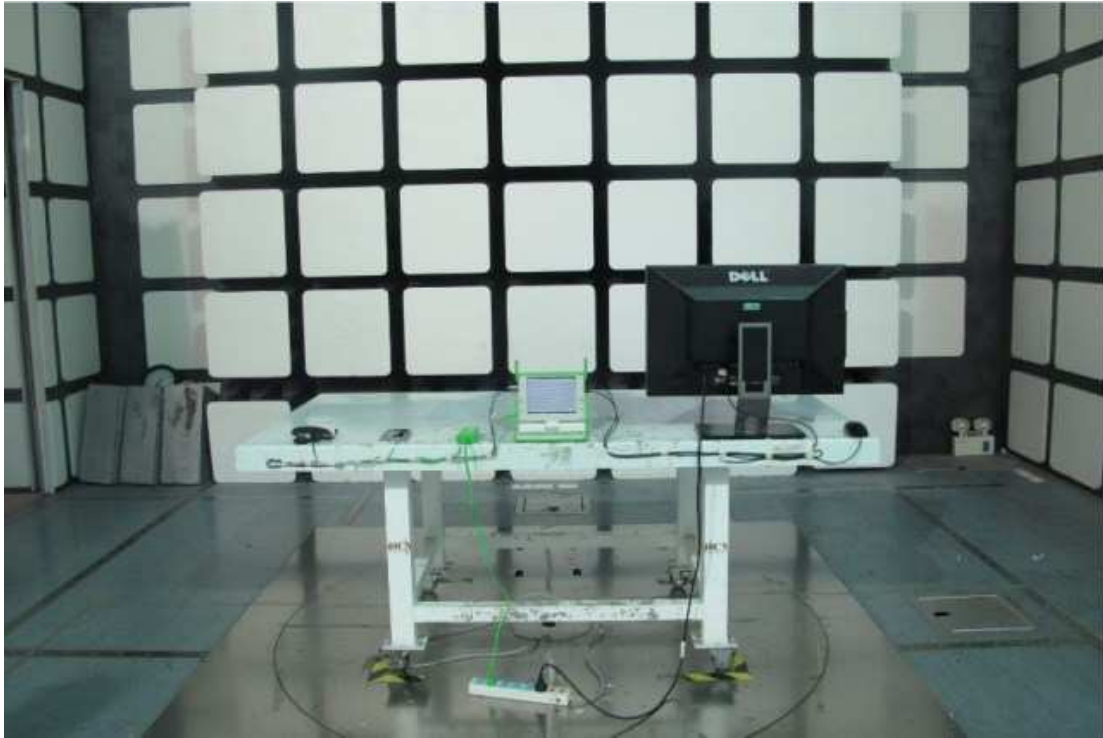

#### 4.6 Fast Transient / Burst Immunity Test





#### 4.7 Surge Immunity Test



#### 4.8 Conducted Disturbance, Induced Radio-Frequency Field Immunity Test





#### 4.9 Power Frequency Magnetic Field Immunity Test



#### 4.10 Voltage Dips / Short Interruptions and Interruptions Test

